



















# KITCHEN EXPERIENCE PRICE LIST 26/27

			ALKIMIA	KONBU	MAKI	N21	O'RAMA	LIBERA	ERGO	YCON	MOONY	X-TREND	REAL	XT	MARVEL	STEEL LINE	REAL STEEL	X-TREND INOX
NEWFORM FINISHES	 <b>21.018</b> CROMO CHROME		●	●	●	●	●	●	●	●	●	●	●	●	●			
	 <b>01.014</b> BIANCO OPACO MATT WHITE		●							●								
	 <b>01.093</b> NERO OPACO MATT BLACK		●	●	●	●	●	●			●	●			●			
	 <b>47.083</b> GROOVE BRONZE															●		
	 <b>31.028</b> BRUSHED NICKEL			●	●	●	●	●			●	●	●	●	●	●		
PVD	 <b>43.238</b> ANTRACITE ANTHRACITE												●					
	 <b>59.064</b> BRUSHED GUN METAL		●	●	●	●	●	●		●	●		●					
	 <b>59.066</b> BRUSHED STAINLESS STEEL		●	●	●	●	●	●		●	●							
	 <b>59.067</b> BRUSHED COPPER BRONZE		●	●	●	●	●	●			●	●		●				
	 <b>59.098</b> BRUSHED PALE GOLD		●	●	●	●					●			●				
EXCLUSIVE METAL	 <b>M0.077</b> CARBON SATIN		●	●	●	●	●	●		●	●							
	 <b>S0.165</b> SOFT EUCALYPT		●	●														
SOFT COLOR	 <b>S0.166</b> SOFT CORTEX		●	●														
	 <b>S0.167</b> SOFT MAPLE		●	●														
	 <b>S0.169</b> SOFT NAVY		●															
INOX	 <b>50.050</b> ACCIAIO INOX STAINLESS STEEL															●	●	●

*"La vera bellezza del design è contenuta nell'abilità di raccontare storie senza parole,  
suscitando emozioni capaci di toccare il cuore e affascinare la mente"*

LASCIATI ISPIRARE

---

*"The true beauty of design lies in its ability to tell stories without words,  
evoking emotions that touch the heart and captivate the mind"*

BE INSPIRED

---

*"La véritable beauté du design réside dans sa capacité à raconter des histoires sans mots,  
en suscitant des émotions qui touchent le cœur et captivent l'esprit"*

LAISSEZ-VOUS INSPIRER

---

*"Die wahre Schönheit des Designs liegt in der Fähigkeit, Geschichten ohne Worte zu erzählen,  
Emotionen zu wecken, die in der Lage sind, das Herz zu berühren und den Verstand zu faszinieren"*

LASSEN SIE SICH INSPIRIEREN

---

*"La verdadera belleza del design radica en su capacidad de contar historias sin palabras,  
evocando emociones que tocan el corazón y encantan la mente"*

DÉJATE INSPIRAR

# INDEX

## 00 INTRO

P. 6	<b>WE ARE NEWFORM</b>
P. 9	<b>SUSTAINABILITY</b>
P. 10	<b>SAVE WATER</b>
P. 17	<b>ENVIRONMENT</b>
P. 21	<b>ITALIAN PERSONALITY</b>
P. 25	<b>INNOVATION</b>
P. 28	<b>PRODUCT CERTIFICATIONS</b>
P. 30	<b>FINISHES</b>
P. 37	<b>STAINLESS STEEL</b>
P. 38	<b>BRASS</b>
P. 40	<b>LEGENDA ICONE / <i>KEY TO ICONS</i></b>

# 01

## KITCHEN EXPERIENCE

P. 44	<b>ALKIMIA</b>	<hr/>
P. 60	<b>KONBU</b>	
P. 66	<b>MAKI</b>	
P. 72	<b>N21</b>	
P. 78	<b>O'RAMA</b>	
P. 82	<b>LIBERA</b>	
P. 86	<b>ERGO</b>	
P. 92	<b>YCON</b>	
P. 98	<b>MOONY</b>	
P. 106	<b>X-TREND</b>	
P. 112	<b>REAL</b>	
P. 118	<b>XT</b>	
P. 124	<b>MARVEL</b>	<hr/>
P. 128	<b>new STEEL LINE</b>	<hr/>
P. 138	<b>REAL STEEL</b>	
P. 144	<b>X-TREND INOX</b>	<hr/>

BRASS

STEEL



ALKIMIA

- 21.018    ● 59.098
- 01.014    ● S0.165
- 01.093    ● S0.166
- 59.064    ● S0.167
- 59.066    ● S0.169
- 59.067    ● M0.077



KONBU

- 21.018    ● 59.098
- 01.093    ● S0.165
- 31.028    ● S0.166
- 59.064    ● S0.167
- 59.066    ● M0.077
- 59.067



MAKI

- 05.093    ● 57.066
- 01.093    ● 57.067
- 33.093    ● 57.098
- 57.064    ● M2.077



N21

- 21.018    ● 59.066
- 01.093    ● 59.067
- 31.028    ● 59.098
- 59.064    ● M0.077



O'RAMA

- 05.093    ● 57.066
- 01.093    ● 57.067
- 33.093    ● M2.077
- 57.064



LIBERA

- 21.018    ● 59.064
- 01.093    ● 59.066
- 05.093    ● 59.067
- 31.028    ● M2.077



ERGO

- 21.018



YCON

- 21.018    ● 59.066
- 01.014    ● 59.067
- 01.093    ● 59.098
- 31.028    ● M0.077
- 59.064



MOONY

- 21.018   ● 59.066
- 01.093   ● 59.067
- 31.028   ● M0.077
- 59.064



X-TREND

- 21.018   ● 31.028



REAL

- 21.018   ● 59.064
- 31.028   ● 59.067
- 43.238   ● 59.098



XT

- 21.018   ● 31.028
- 01.093

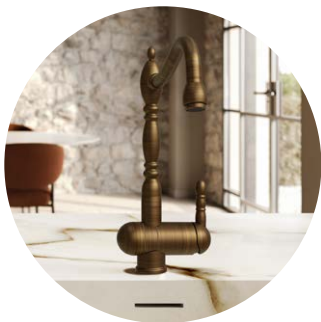

MARVEL

- 21.018   ● 31.028
- 47.083



STEEL LINE

- 50.050   ● 01.093



REAL STEEL

- 50.050



X-TREND INOX

- 50.050

## ● PARLIAMO DI FUTURO DA OLTRE 40 ANNI

Se la storia insegna che i successi del presente sono le fatiche del passato, quello di Newform è molto più che un percorso iniziato nel 1981.

Raccontiamo il vissuto di un'azienda, ma anche di una famiglia e del suo progetto di vita insieme, tra casa e lavoro.

Anno dopo anno l'azienda è cresciuta fino a diventare una delle grandi protagoniste del mondo dell'arredo bagno e cucina, assumendo una posizione di rilievo tra la rubinetteria d'alta gamma. In un periodo in cui sembrava non ci fosse più nulla da inventare e da proporre in questo settore, Newform con coraggio ha saputo osare, investendo e introducendo prodotti dal design altamente innovativo, in linea con le evoluzioni dell'abitare.

Oggi l'azienda si compone di una consolidata rete di partner mondiali, l'energia motrice di cambiamenti e continui miglioramenti, il cui feedback è sempre il primo strumento di misura per evolvere ed andare oltre, verso il futuro.

### ● OVER 40 YEARS OF FUTURE VISION

*If history teaches that the successes of the present are the labours of the past, Newform's is much more than an adventure that began in 1981. It tells the story of a company, but also of a family and its life project together, between home and work.*

*Year after year, the company has grown to become one of the major players in the world of bathroom and kitchen furnishing, assuming a prominent position among top-of-the-range taps and fittings. At a time when there seemed to be nothing left to invent and to propose in this sector, Newform courageously dared, investing and introducing highly innovative design products in line with the evolution of living.*

*Today, the company is made up of a consolidated network of worldwide partners, the driving force behind changes and continuous improvements, whose feedback is always the first measure to evolve and go further, towards the future.*

### ● UNE VISION DU FUTUR DEPUIS 40 ANS

*Si l'histoire enseigne que les réussites du présent sont les adversités du passé, celui de Newform est bien plus qu'un parcours qui a commencé en 1981. Nous racontons le vécu d'une entreprise, mais aussi d'une famille et de son projet de vie ensemble, entre maison et travail.*

*D'année en année, l'entreprise s'est développée pour devenir une des grandes protagonistes du monde de l'ameublement salle de bains et cuisine, pour occuper une place importante dans le secteur des robinets haut de gamme. Durant une période au cours de laquelle il semblait qu'il ne restait rien à inventer ni à proposer dans ce secteur, Newform a su oser, pour investir et créer des produits au design hautement innovant, conformes aux évolutions de l'habitat.*

*Aujourd'hui, l'entreprise se compose d'un réseau bien affirmé de partenaires mondiaux, le moteur de changements et d'améliorations constantes, dont les commentaires sont toujours l'instrument de mesure pour évoluer et aller au-delà, vers l'avenir.*

### ● SEIT ÜBER 40 JAHREN GESTALTEN WIR DIE ZUKUNFT

*Wenn die Geschichte die Erfahrung lehrt, dass die Erfolge der Gegenwart die Mühen der Vergangenheit sind, so ist die Reise von Newform viel mehr als nur eine Reise, die im Jahr 1981 begann. Wir erzählen die Geschichte eines Unternehmens, aber auch die einer Familie und ihres Lebensprojekts, das sich zwischen Zuhause und der Arbeit abspielt.*

*Jahr für Jahr hat sich das Unternehmen zu einem wichtigen Akteur in der Welt der Bad- und Küchenarmaturen entwickelt und nimmt eine herausragende Stellung unter den High-End-Armaturen ein. Zu einem Zeitpunkt, als es in diesem Sektor nichts mehr zu entwickeln und anzubieten gab, wagte Newform den Mut, zu investieren und hochinnovative Designprodukte einzuführen, die mit der Evolution des Wohnens im Einklang stehen.*

*Heute besteht das Unternehmen aus einem gut etablierten Netzwerk globaler Partner, die die treibende Kraft hinter dem Wandel und der kontinuierlichen Verbesserung sind und deren Feedback immer die erste Maßnahme ist, um sich weiterzuentwickeln und der Zukunft entgegenzugehen.*

### ● 40 AÑOS MIRANDO HACIA EL FUTURO

*Si la historia enseña que los éxitos del presente son las fatigas del pasado, el de Newform es mucho más que un camino iniciado en 1981. Hablamos de la experiencia de una empresa, pero también de una familia y de su proyecto de vida juntos, entre el hogar y el trabajo.*

*Año tras año, la empresa ha crecido hasta convertirse en una de las grandes protagonistas del mundo del equipamiento para baño y cocina, asumiendo una posición destacada entre la grifería de alta gama. En una época en la que parecía que ya no quedaba nada por inventar y proponer en este sector, Newform supo atreverse con valentía, invirtiendo e introduciendo productos con un diseño altamente innovador, en línea con la evolución del uso del hogar.*

*En la actualidad, la empresa se compone de una red consolidada de socios mundiales, energía impulsora de los cambios y las mejoras continuas, cuyo feedback es siempre el primer instrumento de medición para evolucionar y cruzar límites, hacia el futuro.*



GUARDA IL VIDEO  
WATCH THE VIDEO  
REGARDEZ LA VIDÉO  
SCHAUEN SIE SICH DAS VIDEO AN  
VER EL VÍDEO

A photograph of a modern, multi-story building with a prominent glass dome structure. The building features large windows and a central entrance area with a tree. The text "WE ARE NEWFORM" is overlaid in white, bold, sans-serif font across the middle of the image. The foreground shows a paved walkway, green grass, and a bush of white roses.

**WE ARE NEWFORM**

A scenic mountain valley at sunrise or sunset. The sun is low on the horizon, casting a warm, golden glow over the landscape. In the foreground, a river flows through a lush green forest. To the right, a stone wall separates the river from a vibrant green field. In the middle ground, a small village with several buildings is nestled in the valley. The background shows misty, forested mountains under a soft sky with scattered clouds.

# SUSTAINABILITY

## BENESSERE COME VALORE SOCIALE

Vivere e operare secondo un'etica sostenibile, creando valore per il territorio intorno a noi. Un impegno diventato il modus operandi dell'attività di Newform, nonché il mantenimento di una promessa iniziata nel 2007, anno in cui è stata ottenuta la Certificazione UNI EN ISO 14001 del Sistema di Gestione Ambientale per la sede storica sita a Vintebbio (VC). Consideriamo questa certificazione ambientale come il primo strumento attraverso cui Newform garantisce i propri risultati in termini di politica ambientale, migliorando le performance e minimizzando ogni possibile impatto negativo della sua attività nei confronti dell'ambiente. Attraverso questa norma l'azienda è in grado di promuovere in maniera sistematica il raggiungimento delle prestazioni e degli obiettivi ambientali, migliorando la propria attività secondo una pianificazione strategica degli interventi. Una misura che punta al benessere dell'azienda e dell'ambiente circostante, così come espresso nella "Politica per la Qualità, l'Ambiente e la Sicurezza".

Newform considera, infatti, la diffusione della cultura della qualità, del rispetto per l'ambiente e dell'attenzione alla salute e sicurezza nei luoghi di lavoro come aspetti fondamentali per il processo di crescita aziendale, di sviluppo del proprio personale, dei propri clienti, fornitori e, più in generale, della comunità.

Nel corso degli anni, abbiamo creato quella che definiamo la nostra comfort zone di benessere sociale grazie al forte legame con i luoghi che ci circondano. Una sintonia a 360° con il territorio intorno a noi che non solo implica un essenziale spirito sostenibile, ma predilige il coinvolgimento e la selezione costante di fornitori e dipendenti locali. Svolgiamo la nostra attività con la migliore intenzione di integrare e mantenere all'interno di Newform l'impronta del nostro territorio e del valore Made in Italy.

### WELL-BEING AS A SOCIAL VALUE

*Living and operating according to sustainable ethics, creating value for the territory around us. A commitment that has become the modus operandi of Newform's activity, as well as the fulfilment of a promise begun in 2007, the year in which the UNI EN ISO 14001 Certification of the Environmental Management System was obtained for the historical headquarters located in Vintebbio (VC). We see this environmental certification as the first tool through which Newform guarantees its results in terms of environmental policy, improving performance and minimising any possible negative impact of its activities on the environment.*

*Through this standard, the company is able to systematically promote the achievement of environmental performance and objectives, improving its activities according to strategic planning of interventions. A measure that aims at the well-being of the company and the surrounding environment, as expressed in the "Quality, Environment and Safety Policy". Newform considers, in fact, the dissemination of the culture of quality, respect for the environment and attention to health and safety in the workplace as fundamental aspects for the process of corporate growth, development of its staff, its customers, suppliers and, more generally, the community.*

*Over the years, we have created what we call our social comfort zone thanks to our strong connection with the local area around us. All-round harmony with the territory around us not only implies an essential sustainable spirit but also favours the involvement and constant selection of local suppliers and employees. We carry out our activity with the best intention of integrating and maintaining the imprint of our territory and Made in Italy value in Newform.*

### LE BIEN-ÊTRE EN TANT QUE VALEUR SOCIALE

*Vivre et opérer suivant une éthique durable, en créant de la valeur pour le territoire qui nous entoure. Un engagement devenu le modus operandi de l'activité de Newform, ainsi que le maintien d'une promesse qui a pris forme en 2007, année de l'obtention de la Certification UNI EN ISO 14001 du Système de Gestion Environnementale pour le siège historique qui se situe à Vintebbio (VC). À nos yeux, cette certification environnementale est le premier instrument avec lequel Newform garantit ses résultats en termes de politique environnementale, en améliorant les performances et en réduisant le plus possible l'impact négatif de ses activités vis à vis de l'environnement.*

*Grâce à cette norme, l'entreprise est en mesure de promouvoir de manière systématique la réalisation des performances et des objectifs environnementaux, en améliorant son activité suivant une planification stratégique des interventions. Une mesure qui vise au bien-être de l'entreprise et de l'environnement alentour, tel qu'exprimé dans la "Politique pour la Qualité, l'Environnement et la Sécurité". En effet, Newform considère la diffusion de la culture de la qualité, du respect pour l'environnement et de l'attention à la santé et à la sécurité sur les lieux de travail comme des aspects fondamentaux pour le processus de croissance de l'entreprise, de développement de son personnel, de ses clients, de ses fournisseurs et, plus en général, de la communauté.*

*Avec les années, nous avons créé ce que nous définissons notre zone de confort de bien-être social grâce au lien fort avec les lieux qui nous entourent. Une harmonie à 360° avec notre territoire qui implique non seulement un esprit durable essentiel, mais qui privilégie aussi l'implication et la sélection constante de fournisseurs et d'employés locaux. Nous exerçons notre activité avec la plus grande attention pour intégrer et maintenir au sein de Newform l'empreinte de notre territoire et de la valeur Made in Italy.*

### WOHLBEFINDEN ALS GESELLSCHAFTLICHER WERT

*Wir leben und arbeiten nach einer nachhaltigen Ethik und schaffen Werte für unsere Umgebung. Eine Verpflichtung, die für Newform zum modus operandi geworden ist, ebenso wie die Erfüllung eines Versprechens, das im Jahr 2007 begonnen wurde, dem Jahr, in dem die UNI EN ISO 14001 Zertifizierung des Umweltmanagementsystems für den historischen Hauptsitz in Vintebbio (VC) erhalten wurde. Wir betrachten diese Zertifizierung für den Umweltschutz als das erste Instrument, mit dem Newform seine Ergebnisse in Bezug auf die Umweltpolitik, die Verbesserung der Leistung und die Minimierung möglicher nachteiliger Auswirkungen seiner Aktivitäten auf die Umwelt garantiert.*

*Mit diesem Standard kann das Unternehmen die Erreichung von Umwelleistungen und -zielen systematisch fördern und sein Geschäft entsprechend einer strategischen Planung von Maßnahmen verbessern. Diese Maßnahme zielt auf das Wohlergehen des Unternehmens und seiner Umwelt ab, wie es in der "Politik für Qualität, Umwelt und Sicherheit" zum Ausdruck kommt. Newform sieht die Verbreitung der Qualitätskultur, den Respekt für die Umwelt und die Aufmerksamkeit für Gesundheit und Sicherheit am Arbeitsplatz als grundlegende Aspekte für den Prozess des Unternehmenswachstums, der Entwicklung seiner Mitarbeiter, seiner Kunden, seiner Lieferanten und ganz allgemein der Gemeinschaft.*

*Im Laufe der Jahre haben wir dank unserer starken Bindung an die Orte um uns herum das geschaffen, was wir unsere sogenannte soziale Komfortzone nennen. Eine räumlich harmonische Verbindung mit unserer Region, die nicht nur einen nachhaltigen Geist voraussetzt, sondern auch die Einbeziehung und ständige Auswahl lokaler Lieferanten und Mitarbeiter begünstigt. Wir betreiben unsere Tätigkeit in der bestmöglichen Absicht, die Prägung unseres Territoriums und den Wert des Made in Italy in Newform zu integrieren und zu erhalten.*

### BIENESTAR COMO VALOR SOCIAL

*Vivir y operar de acuerdo con una ética sostenible, creando valor para el territorio que nos rodea. Un compromiso que se ha convertido en el modus operandi de la actividad de Newform, así como en el cumplimiento de una promesa iniciada en 2007, año en el que se obtuvo la Certificación UNI EN ISO 14001 del Sistema de Gestión Ambiental para la sede histórica situada en Vintebbio (VC). Consideramos esta certificación ambiental como la primera herramienta a través de la cual Newform garantiza sus resultados en términos de política ambiental, mejorando el rendimiento y minimizando cualquier posible impacto negativo de su actividad sobre el medio ambiente.*

*A través de esta norma, la empresa es capaz de promover de forma sistemática el logro de resultados y objetivos medioambientales, mejorando su actividad de acuerdo con una planificación estratégica de las intervenciones. Una medida que apunta al bienestar de la empresa y del entorno, tal y como se expresa en la "Política de Calidad, Medio Ambiente y Seguridad". Para Newform, la difusión de la cultura de la calidad, del respeto por el medio ambiente y de la atención a la salud y la seguridad en el lugar de trabajo son aspectos fundamentales para el proceso de crecimiento empresarial, de desarrollo de su personal, de sus clientes, proveedores y, manera general, de la comunidad.*

*A lo largo de los años, hemos creado lo que llamamos nuestra zona de confort de bienestar social gracias a la fuerte conexión con los lugares que nos rodean. Una sintonía de 360° con el territorio que nos rodea que no solo implica un espíritu sostenible esencial, sino que favorece la participación y la selección constante de proveedores y empleados locales. Desarrollamos nuestra actividad con la mejor intención de integrar y mantener dentro de Newform la huella de nuestro territorio y del valor Made in Italy.*

## ACQUA, PATRIMONIO VITALE

Esiste una speciale sintonia tra Newform e l'acqua, un'inevitabile ispirazione e un senso di dovere dell'azienda verso l'elemento naturale senza cui i propri prodotti non avrebbero funzionalità.

Il forte legame con il territorio che ci circonda e l'estrema attenzione verso i luoghi che da sempre ci ospitano, impongono tra le nostre priorità la tutela dell'ambiente e la salvaguardia delle risorse idriche.

I tempi moderni ci rendono coscienti di come la protezione di un bene prezioso come l'acqua cominci dai gesti e dalle scelte quotidiane di ognuno di noi. Per tale ragione, con i propri progetti Newform si impegna a promuovere una cultura ecologica che porti ad un uso più efficiente e oculato dell'acqua al fine di minimizzare il proprio impatto sull'ambiente.

Ci impegniamo quotidianamente affinché le attività che svolgiamo avvengano in armonia con ciò che ci circonda, senza alterare l'equilibrio naturale del territorio che da sempre consideriamo come casa. Pertanto, riconoscendo il valore di ogni risorsa naturale, dedichiamo un'importante parte del nostro tempo ad attenti e costanti controlli, oltre che specifiche analisi, per "restituire" l'acqua alla sua fonte originaria, così come richiesto dalle norme di legge. Questo è quanto definiamo come il lungo accordo tra Newform e l'ambiente ispirato al remoto principio del "do ut des", in cui l'azienda riconosce il suo ruolo da principale debitrice.

Dove affondiamo le nostre radici, lì inizia il dovere del rispetto e della tutela di ogni elemento del nostro territorio. Una forma di coesistenza primordiale tra uomo e natura della quale oggi siamo parte integrante.

### THE VITAL HERITAGE OF WATER

*There is a special harmony between Newform and water, an inevitable inspiration and a sense of duty of the company towards the natural element without which our products would have no functionality.*

*Our strong ties with the territory that surrounds us and our extreme care for the places that have always hosted us make environmental protection and the safeguarding of water resources one of our priorities.*

*Modern times make us aware of how the protection of a precious commodity like water begins with the daily gestures and choices of each one of us. This is why Newform is committed to promoting an ecological culture with its projects that lead to the more efficient and prudent use of water to minimise its impact on the environment.*

*We strive to ensure that our activities take place in harmony with our surroundings on a daily basis, without altering the natural balance of the land that we have always considered home. Therefore, appreciative of the value of every natural resource, we dedicate an important part of our time to careful and constant controls, as well as specific analyses, to "return" water to its original source, as required by law. This is what we define as the long-lasting agreement between Newform and the environment inspired by the remote principle of "quid pro quo", in which the company recognises its role as the main debtor.*

*Our duty to respect and protect every element of our territory starts exactly from where we are deeply rooted. A form of primordial coexistence between man and nature of which we are now an integral part.*

### L'EAU PATRIMOINE VITAL

*Il existe une harmonie spéciale entre Newform et l'eau, une inspiration inévitable et un sens de devoir de l'entreprise à l'égard de l'élément naturel sans lesquels ses produits n'auraient pas de fonctionnalité. Le lien étroit avec le territoire qui nous entoure et l'attention extrême à l'égard des lieux qui nous accueillent depuis toujours imposent parmi nos priorités la protection de l'environnement et la sauvegarde des ressources en eau.*

*Les temps modernes nous font comprendre combien la protection d'un bien précieux comme l'eau part des gestes et des choix quotidiens de chacun d'entre nous. C'est pour cela que Newform, avec ses projets, s'engage à promouvoir une culture écologique qui conduit à une utilisation plus efficace et judicieuse de l'eau afin de minimiser son impact sur l'environnement.*

*Nous nous engageons chaque jour afin que les activités que nous exerçons se fassent en harmonie avec ce qui nous entoure, sans altérer l'équilibre naturel du territoire que nous considérons depuis toujours comme notre chez-nous. C'est pour cela que, reconnaissant de la valeur de chaque ressource naturelle, nous consacrons une partie importante de notre temps à des contrôles attentifs et constants, en plus d'analyses spécifiques, afin de "restituer" l'eau à sa source d'origine, tel qu'imposé par les dispositions légales. Voilà ce que nous désignons comme l'accord de grande longévité entre Newform et l'environnement qui s'inspire du principe du do ut des, où l'entreprise reconnaît son rôle en tant que principale redevable.*

*C'est là où nous plongeons nos racines que le devoir du respect et de la protection de chaque élément de notre territoire commence. Une forme de coexistence primordiale entre homme et nature dont nous faisons aujourd'hui partie intégrante.*

### WASSER ALS LEBENSWICHTIGES GUT

*Es herrscht eine besondere Harmonie zwischen Newform und dem Wasser, eine unausweichliche Inspiration und ein Pflichtgefühl des Unternehmens gegenüber dem natürlichen Element, ohne das seine Produkte nicht funktionieren würden. Durch unsere enge Verbundenheit mit dem Gebiet, das uns umgibt, und unsere große Sorge um die Orte, die schon immer unser Zuhause waren, gehören der Umweltschutz und der Schutz der Wasserressourcen zu unseren Prioritäten.*

*In der heutigen Zeit wird uns bewusst, dass der Schutz eines kostbaren Guts wie Wasser mit den täglichen Gesten und Entscheidungen eines jeden von uns beginnt. Aus diesem Grund setzt sich Newform mit seinen Projekten für eine ökologische Kultur ein, die zu einem effizienteren und vernünftigen Umgang mit Wasser führt, um die Auswirkungen auf die Umwelt zu minimieren.*

*Wir sind täglich bestrebt, sicherzustellen, dass die Aktivitäten, die wir durchführen, im Gleichgewicht mit unserer Umgebung sind, ohne dabei das natürliche Gleichgewicht des Landes zu verändern, das wir schon immer als unsere Heimat betrachtet haben. In Anerkennung des Wertes jeder natürlichen Ressource widmen wir daher einen wichtigen Teil unserer Zeit sorgfältigen und ständigen Kontrollen sowie spezifischen Analysen, um das Wasser, wie gesetzlich vorgeschrieben, in seine ursprüngliche Quelle "zurückzuführen". Darunter verstehen wir die seit langem bestehende Abmachung zwischen Newform und der Umwelt, die sich an dem entfernten Prinzip der Gegenleistung orientiert, bei dem das Unternehmen seine Rolle als Hauptschuldner anerkennt.*

*Dort, wo wir unsere Wurzeln schlagen, erwächst uns die Pflicht, jedes Element unseres Territoriums zu respektieren und zu schützen. Eine ursprüngliche Form der Koexistenz zwischen Mensch und Natur, von der wir heute ein fester Bestandteil sind.*

### AGUA, PATRIMONIO VITAL

*Existe una sintonia especial entre Newform y el agua, una inspiración inevitable y un sentido de deber de la empresa hacia el elemento natural sin el cual sus productos no tendrían razón de ser.*

*El fuerte vínculo con el territorio que nos rodea y la extrema atención a los lugares que siempre nos han albergado, imponen entre nuestras prioridades la protección del medio ambiente y la salvaguarda de los recursos hídricos.*

*Los tiempos modernos nos hacen conscientes de cómo la protección de un bien precioso como el agua comienza con los gestos y las elecciones cotidianas de cada uno de nosotros. Por esta razón, a través de sus proyectos Newform se compromete a promover una cultura ecológica que conduzca a un uso más eficiente y cuidadoso del agua con el fin de minimizar su impacto en el medio ambiente.*

*Nos esforzamos diariamente para que las actividades que realizamos se hagan en armonía con nuestro entorno, sin alterar el equilibrio natural del territorio que siempre hemos considerado como nuestra casa. De este modo, agradecidos por el valor de cada recurso natural, dedicamos una parte importante de nuestro tiempo a controles cuidadosos y constantes, así como a análisis específicos, para "devolver" el agua a su fuente original, tal y como exigen las normas legales. Esto es lo que definimos como el prolongado acuerdo entre Newform y el entorno inspirado en el remoto principio del "do ut des", en el que la empresa reconoce su papel como principal deudora.*

*Donde hundimos nuestras raíces, allí comienza el deber de respetar y proteger cada elemento de nuestro territorio. Una forma de coexistencia primordial entre el hombre y la naturaleza de la que hoy somos parte integrante.*

An aerial photograph of a beach. The top half of the image shows the ocean with white, foamy waves crashing onto the shore. The bottom half shows the sandy beach, which is a warm, reddish-brown color. Numerous white birds, likely seagulls, are scattered across the beach, some standing and some in flight. The overall scene is serene and natural.

**SAVE WATER**



**SAVE  
WATER**



Pensiamo e agiamo in funzione di una coscienza sostenibile che nel corso della nostra storia ci ha spinti a progettare e realizzare i prodotti Save Water, la promessa e l'impegno concreto dell'azienda in nome dell'Ambiente e della Sostenibilità. In un periodo in cui si diffonde sempre più la consapevolezza di preservare l'acqua in quanto bene essenziale e limitato, Newform decide di agire, consapevole di quanto la propria attività e soprattutto i propri prodotti implicino un costante utilizzo di questa risorsa naturale.

Con la gamma Save Water nascono i nuovi miscelatori a risparmio idrico che non solo permettono di ridurre gli sprechi, ma assicurano anche una notevole diminuzione dei consumi di acqua e di energia. Con i prodotti delle collezioni contrassegnate dal simbolo Save Water, la portata ridotta assicura un minore consumo di acqua, con un conseguente risparmio idrico fino al 50%.



*We think and act according to a sustainable conscience that throughout our history has driven us to design and manufacture Save Water products, the company's promise and concrete commitment in the name of the Environment and Sustainability. At a time when there is a growing awareness of preserving water as an essential and limited asset, Newform decides to take action, aware of how much its business and especially its products involve constant use of this natural resource.*

*The Save Water range introduces new water-saving mixers that not only reduce waste but also ensure a significant reduction in water and energy consumption. The products in the collections marked with the Save Water symbol provide a reduced flow rate, resulting in water savings of up to 50%.*



*Wir denken und handeln nach einem nachhaltigen Bewusstsein, das uns im Laufe unserer Geschichte dazu gebracht hat, Save Water-Produkte zu entwerfen und herzustellen, das Versprechen und die konkrete Verpflichtung des Unternehmens gegenüber der Umwelt und der Nachhaltigkeit. Zu einem Zeitpunkt, an dem das Bewusstsein für den Schutz des Wassers als lebenswichtiges und begrenztes Gut wächst, beschließt Newform zu handeln, da das Unternehmen und vor allem seine Produkte eine ständige Nutzung dieser natürlichen Ressource erfordern.*

*Mit der Save Water-Reihe kommen neue wassersparende Mischer auf den Markt, die nicht nur den Abfall reduzieren, sondern auch für eine deutliche Senkung des Wasser- und Energieverbrauchs sorgen. Bei Produkten aus den Linien, die mit dem Save Water-Symbol gekennzeichnet sind, gewährleistet die reduzierte Durchflussmenge einen geringeren Wasserverbrauch, was zu einer Wassereinsparung von bis zu 50% führt.*



Nous pensons et nous agissons selon une conscience durable qui, au cours de notre histoire, nous a poussés à concevoir et à réaliser les produits Save Water, la promesse et l'engagement concret de l'entreprise au nom de l'Environnement et de la Durabilité. Durant un période où la conscience de préserver l'eau en tant que bien essentiel et limité se diffuse en plus en plus, Newform décide d'agir, consciente du fait que son activité et surtout ses produits impliquent l'utilisation constante de cette ressource naturelle.

La gamme Save Water donne naissance aux nouveaux mitigeurs économie d'eau. Ceux-ci permettent de réduire les gaspillages tout en assurant une diminution considérable des consommations d'eau et d'énergie. Avec les produits des collections marquées avec le symbole Save Water, le débit réduit assure une consommation d'eau réduite, avec une économie d'eau qui va jusqu'à 50%.



Pensamos y actuamos en función de una conciencia sostenible que a lo largo de nuestra historia nos ha impulsado a diseñar y fabricar los productos Save Water, la promesa y el compromiso concreto de la empresa en nombre del medioambiente y la sostenibilidad. En un período en el que se difunde cada vez más la conciencia de preservar el agua como un bien esencial y limitado, Newform decide actuar, consciente de que su actividad y, sobre todo, sus productos implican un uso constante de este recurso natural.

Con la gama Save Water nacen los nuevos mezcladores de ahorro de agua que no solo permiten reducir el derroche, sino que también aseguran una disminución significativa en el consumo de agua y energía. Con los productos de las colecciones marcadas con el símbolo Save Water, el caudal reducido garantiza un menor consumo de agua, con un consiguiente ahorro de agua de hasta el 50%.



Un prodotto di qualità si riconosce anche dalla sua essenza, ovvero dal materiale che lo compone, verso cui Newform ripone grande attenzione e controllo. Coscienti del fatto che ciò che produciamo costituisce un elemento di quotidiano utilizzo, essenziale e fondamentale alla cura della persona, siamo al lavoro per ampliare la nostra gamma di rubinetti low-lead, a basso contenuto di piombo. Ridurre la percentuale di piombo presente sulla superficie del miscelatore, inevitabilmente a contatto con l'acqua, è un'accortezza che vogliamo estendere a tutti i nostri prodotti per una maggiore sicurezza per la salute umana.

*A high-quality product can be recognised by its essence, in other words the material it is made from, and Newform devotes intense attention and effort to this. Knowing that the items we produce are destined to be used on a daily basis as an essential and fundamental part of personal care, we are working to expand our range of low-lead taps. Reducing the percentage of lead present on the surface of the mixer tap and therefore inevitably in contact with water is a sensible step which we plan to extend to all our products, in the interests of improved safety and human health.*

*Un produit de qualité se reconnaît aussi par son essence, c'est-à-dire par le matériau qui le compose et pour lequel Newform apporte une grande attention et un contrôle particulier. Conscients du fait que ce que nous produisons constitue un élément d'usage quotidien, essentiel et fondamental pour le soin de la personne, nous travaillons pour élargir notre gamme de robinets low-lead, à faible teneur en plomb. Réduire le taux de plomb présent sur la surface du mitigeur, inévitablement en contact avec l'eau, est une mesure que nous voulons étendre à tous nos produits pour une plus grande sécurité pour la santé humaine.*

*Ein Qualitätsprodukt erkennt man auch an seinem Wesen bzw. dem Material, aus dem es gemacht ist, und dem Newform große Aufmerksamkeit widmet und rigorosen Kontrollen unterzieht. Im Bewusstsein, dass das, was wir herstellen, ein alltäglicher Gebrauchsgegenstand ist, der essenziell und fundamental für die Körperpflege ist, arbeiten wir daran, unsere Auswahl an Wasserhähnen low-lead mit geringem Bleigehalt zu erweitern. Den Bleianteil in den Oberflächen der Mischbatterien, die unvermeidlich mit dem Wasser in Kontakt kommen, zu reduzieren, ist eine Umsichtigkeit, die wir auf alle unsere Produkte für eine höhere Sicherheit für die Gesundheit ausweiten wollen.*

*Un producto de calidad también se reconoce por su esencia, es decir, por el material que lo compone, sobre el que Newform ejerce gran atención y control. Conscientes de que lo que producimos constituye un elemento de uso diario, esencial y fundamental para el cuidado personal, trabajamos para ampliar nuestra gama de grifos libres de plomo y con bajo contenido de plomo. Reducir el porcentaje de plomo presente en la superficie del mezclador, inevitablemente en contacto con el agua, es una precaución que queremos extender a todos nuestros productos para una mayor seguridad para la salud humana.*





Energy Saving è il sistema integrato dei miscelatori cucina Newform volto ad implementare il risparmio energetico, ma con un conseguente interesse economico ed ambientale.

Da un'azione semplice come l'ordinaria erogazione dell'acqua dal miscelatore, può dipendere un evidente risparmio di energia. La continua ricerca, infatti, ha permesso di regolare le modalità di erogazione dei rubinetti Newform, già completi della tecnologia Save Water per il risparmio idrico. Grazie al sistema Energy Saving, dalla posizione iniziale della leva, normalmente posta in verticale, è possibile azionare l'erogazione di acqua fredda, mentre è necessario muovere la leva in direzione frontale per erogare acqua calda.

Questo sistema assicura un rilascio controllato di acqua calda a seconda delle necessità, senza incorrere nell'attivazione accidentale o superflua della caldaia.



*The Energy Saving integrated system, which was envisioned for the range of kitchen mixers by Newform, aims to implement energy saving, while providing an economic and environmental benefit.*

*From an action as simple as turning on your faucet, there can be an evident increase in energy saving. Ongoing research has led to the ability to regulate and control how water flows from Newform mixers, which are already integrated with the Save Water technology.*

*Thanks to the Energy Saving system, the cold-start feature is now available on our faucets. Where, from the starting position of the lever, the supply is immediately set on cold water and the lever will have to be moved in a forward direction for hot water. This System provides a controlled release of hot water, without needing to activate the furnace senselessly.*



Le système intégré appelé "Energy Saving" des mitigeurs de cuisine proposés par Newform a été conçu pour assurer des économies d'énergie, tout en offrant des prestations économiques et durables. D'une simple action ordinaire, comme la distribution d'eau d'un mitigeur, peut dépendre d'évidentes économies d'énergie. La recherche constante a permis de développer et améliorer les technologies de diffusion d'eau des mitigeurs Newform, déjà complétés par la technique d'économie d'eau appelée "Save Water".

Le système Energy Saving garantit, par la position de la manette, une distribution initiale d'eau froide. Il faut simplement faire pivoter la manette vers l'avant pour demander un apport d'eau chaude. Il assure ainsi un apport d'eau chaude contrôlé, il limite le déclenchement intempestif de la chaudière de façon volontaire et empêche ainsi toute consommation d'énergie superflue.



Energy Saving ist das integrierte System der Newform-Küchenarmaturen, das darauf abzielt, Energie zu sparen, aber gleichzeitig wirtschaftliche und ökologische Vorteile mit sich bringt.

Eine offensichtliche Energieeinsparung kann auf einer einfachen Tätigkeit beruhen, beispielsweise auf der gewöhnlichen Ausgabe von Wasser über die Mischbatterie. Kontinuierliche Forschung hat es tatsächlich ermöglicht, die Abgabemethoden der Newform-Wasserhähne, die bereits mit der Save Water-Technologie zur Wassereinsparung ausgestattet sind, zu regulieren. Dank des Systems Energy Saving ist es aus der Ausgangsposition des Hebels, der normalerweise vertikal angebracht ist, möglich, die Ausgabe von kaltem Wasser zu aktivieren, während es für die Ausgabe von heißem Wasser erforderlich ist, den Hebel nach vorne zu bewegen.

Dieses System gewährleistet eine kontrollierte Abgabe von Warmwasser je nach Bedarf, ohne dass es zu einer versehentlichen oder unnötigen Aktivierung des Heizkessels kommt.



Energy Saving es el sistema integrado de los mezcladores de baño Newform destinado a implementar el ahorro energético, con el consiguiente interés económico y medioambiental.

De una acción simple como el suministro ordinario de agua del mezclador, puede depender un evidente ahorro de energía. La investigación continua ha permitido ajustar los métodos de dispensación de los grifos Newform, ya equipados con la tecnología Save Water para el ahorro de agua. Gracias al sistema Energy Saving, al girar la palanca en el sentido horario, se activa el flujo de agua fría, mientras que al continuar girando, se inicia el proceso de mezcla con agua caliente.

Este sistema asegura una liberación controlada de agua caliente en función de las necesidades, sin incurrir en la activación accidental o superflua de la caldera.



**ENERGY  
SAVING**

An aerial photograph of a dense, lush green forest. The trees are packed closely together, creating a vibrant green canopy. A small stream or river flows through the forest, visible as a dark, winding path. The word "ENVIRONMENT" is overlaid in white, bold, uppercase letters across the center of the image.

**ENVIRONMENT**

## SOSTENIBILI AL 100%

Avere un dovere nei confronti dell'ambiente e sapere come limitare il proprio impatto su di esso è una consapevolezza che abbiamo sviluppato sin dai primi tempi della nostra attività. Ci impegniamo ad adottare e a diffondere tra clienti e partners, attraverso schede informative specifiche, le giuste e doverose misure per lo smaltimento dei rifiuti, in particolare dei materiali di imballaggio della merce spedita nel mondo. Un invito rivolto soprattutto ai singoli utenti per facilitare loro la raccolta differenziata ed effettuare in modo corretto il riciclo e il recupero. Così facendo Newform concretizza e consolida il suo rispettoso impegno verso l'ambiente e chiude il cerchio di un'attività produttiva svolta nel segno della sostenibilità, dall'inizio alla fine.

### 100% SUSTAINABLE

Caring for the environment and knowing how to limit one's impact on it is something we have developed since the early days of our business. We are committed to adopting and disseminating the right and proper measures for the disposal of waste, in particular packaging materials of our own goods shipped worldwide, to our customers and partners by means of specific information sheets. An invitation addressed above all to individual users to make it easier for them to separate waste and carry out recycling and recovery correctly. By doing so, Newform concretises and consolidates its respectful commitment to the environment and closes the circle of a production activity carried out under the sign of sustainability, from beginning to end.

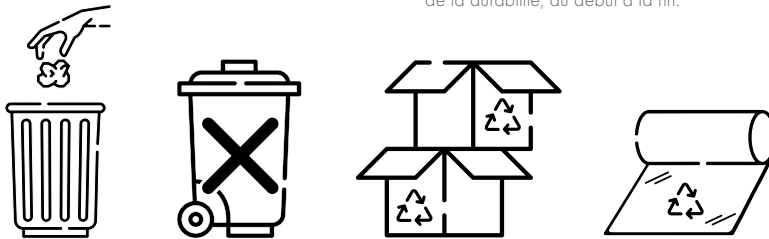

### 100% NACHHALTIG

Wir sind der Umwelt verpflichtet und wissen, wie wir die Auswirkungen auf die Umwelt begrenzen können, ein Bewusstsein, das wir seit den Anfängen unseres Unternehmens entwickelt haben. Wir verpflichten uns, die richtigen und angemessenen Maßnahmen für die Entsorgung von Abfällen, insbesondere von Verpackungsmaterial unserer eigenen, weltweit versendeten Waren, zu ergreifen und sie unseren Kunden und Partnern durch spezifische Informationsblätter mitzuteilen. Eine Aufforderung, die sich vor allem an die einzelnen Nutzer richtet, um ihnen die korrekte Trennung der Abfälle und die Wiederverwertung zu erleichtern. Auf diese Weise konkretisiert und festigt Newform seine respektvolle Verpflichtung gegenüber der Umwelt und schließt den Kreis einer Produktionstätigkeit, die von Anfang bis Ende im Zeichen der Nachhaltigkeit steht.

### 100% DURABLES

Dès les premiers temps de notre activité, nous avons développé la conscience de la nécessité d'avoir une responsabilité à l'égard de l'environnement et de savoir comment limiter notre impact sur celui-ci. Nous nous attachons à adopter et à diffuser auprès de nos clients et partenaires, par le biais de fiches d'information spécifiques, les mesures justes et nécessaires pour l'élimination des déchets, notamment des matériaux d'emballage de leurs marchandises expédiées dans le monde. Cette invitation s'adresse surtout aux simples usagers pour leur faciliter le tri sélectif et permettre le bon déroulement du recyclage et de la récupération. De cette manière, Newform concrétise et consolide son engagement respectueux de l'environnement et clôt le cercle d'une activité productrice à l'enseigne de la durabilité, du début à la fin.

### SOSTENIBILI AL 100%

Tener un deber con el medio ambiente y saber cómo limitar nuestro propio impacto es una conciencia que desarrollamos ya en los primeros días de nuestra actividad. Nos comprometemos a adoptar y difundir entre clientes y socios, a través de fichas informativas específicas, las medidas adecuadas y necesarias para la eliminación de los residuos, en particular de los materiales de embalaje de los productos enviados por todo el mundo. Una invitación dirigida especialmente a los usuarios individuales para facilitarles la recogida selectiva y llevar a cabo correctamente el reciclaje y la recuperación. De esta manera, Newform concreta y consolida su compromiso respetuoso con el medio ambiente y cierra el círculo de una actividad productiva desarrollada en el marco de la sostenibilidad, de principio a fin.



SCOPRI DI PIÙ  
READ MORE  
EN SAVOIR PLUS  
ENTDECKEN SIE MEHR  
OBTÉN MÁS



Una particolare accortezza viene riservata anche ai metodi di pulizia e manutenzione della rubinetteria Newform. Raccomandiamo da sempre l'utilizzo esclusivo di acqua e sapone neutro per pulire le superfici dei miscelatori, evitando così l'uso di detersivi e/o agenti chimici che potrebbero alterare nel tempo la qualità estetica delle finiture, danneggiando esternamente il prodotto. La nostra azienda contribuisce a diffondere una cultura ecologica volta a preservare la salubrità degli spazi del vivere quotidiano, favorendo una maggiore tutela della salute della persona e un minor effetto avverso sull'ambiente.



*Special care is also given to the cleaning and maintenance methods of Newform taps. We have always recommended the exclusive use of water and neutral soap to clean the surfaces of the mixers, thus avoiding the use of detergents and/or chemical agents that could alter the aesthetic quality of the finishes over time, damaging the product externally. Our company contributes to the diffusion of an ecological culture aimed at preserving the healthiness of everyday living spaces, favouring greater protection of people's health and reducing adverse effects on the environment.*



*Nous réservons aussi un soin particulier aux méthodes de nettoyage et d'entretien de la robinetterie Newform. Depuis toujours, nous recommandons l'utilisation exclusive d'eau et de savon neutre pour nettoyer les surfaces des mitigeurs afin d'éviter l'utilisation de détergents et/ou de produits chimiques qui pourraient altérer dans le temps les qualités esthétiques des finitions et endommager l'extérieur du produit. Notre entreprise contribue à diffuser une culture écologique qui vise à préserver la salubrité des espaces de la vie quotidienne, en favorisant une meilleure protection de la santé des personnes et une réduction des impacts négatifs sur l'environnement.*



*Besonderes Aufmerksamkeit gilt auch den Reinigungs und Wartungsmethoden der Armaturen von Newform. Wir haben schon immer empfohlen, für die Reinigung der Oberflächen von Mischern ausschließlich Wasser und neutrale Seife zu verwenden, und die Verwendung von Reinigungsmitteln und/oder chemischen Stoffen zu vermeiden, welche die ästhetische Qualität der Oberfläche im Laufe der Zeit verändern und das Produkt äußerlich beschädigen könnten. Unser Unternehmen trägt zur Verbreitung einer ökologischen Kultur bei, die darauf abzielt, die Gesundheit in den alltäglichen Lebensräumen zu erhalten, die Gesundheit der Menschen besser zu schützen und die Umwelt weniger zu belasten.*



*También prestamos especial atención a los métodos de limpieza y mantenimiento de la grifería Newform. Desde siempre recomendamos el uso exclusivo de agua y jabón neutro para limpiar las superficies de los mezcladores, evitando así el uso de detergentes o agentes químicos que podrían alterar con el tiempo la calidad estética de los acabados, dañando externamente el producto. Nuestra empresa contribuye a difundir una cultura ecológica destinada a preservar la salubridad de los espacios de la vida cotidiana, favoreciendo una mayor protección de la salud de la persona y un menor efecto adverso sobre el medio ambiente.*



SCOPRI DI PIÙ  
READ MORE  
EN SAVOIR PLUS  
ENTDECKEN SIE MEHR  
OBTÉN MÁS

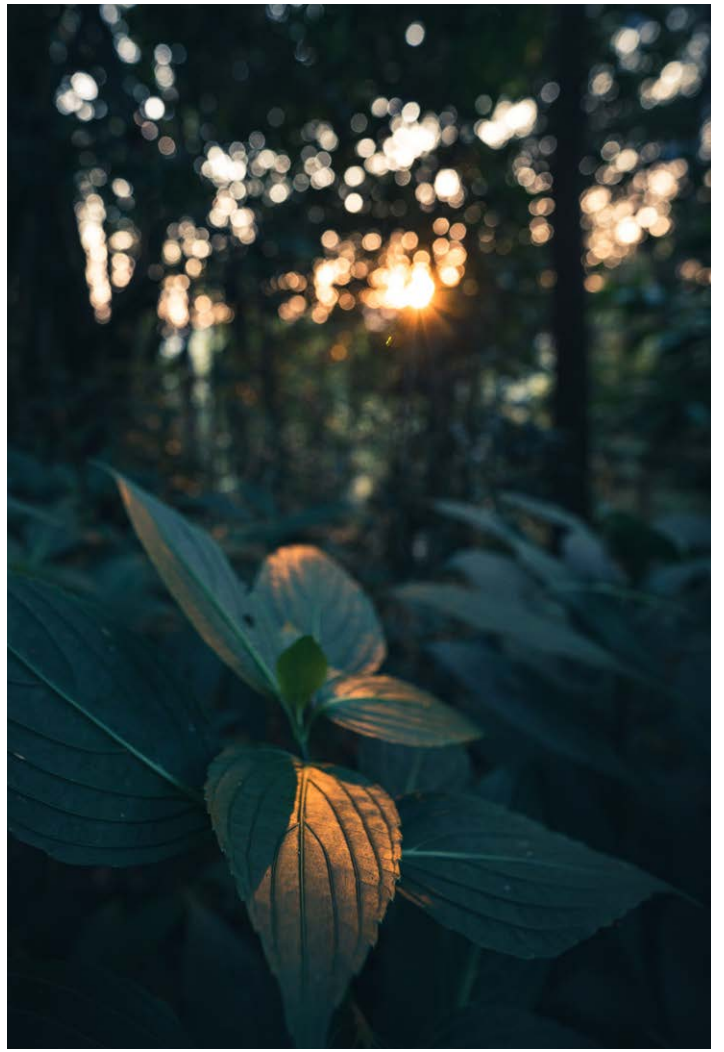
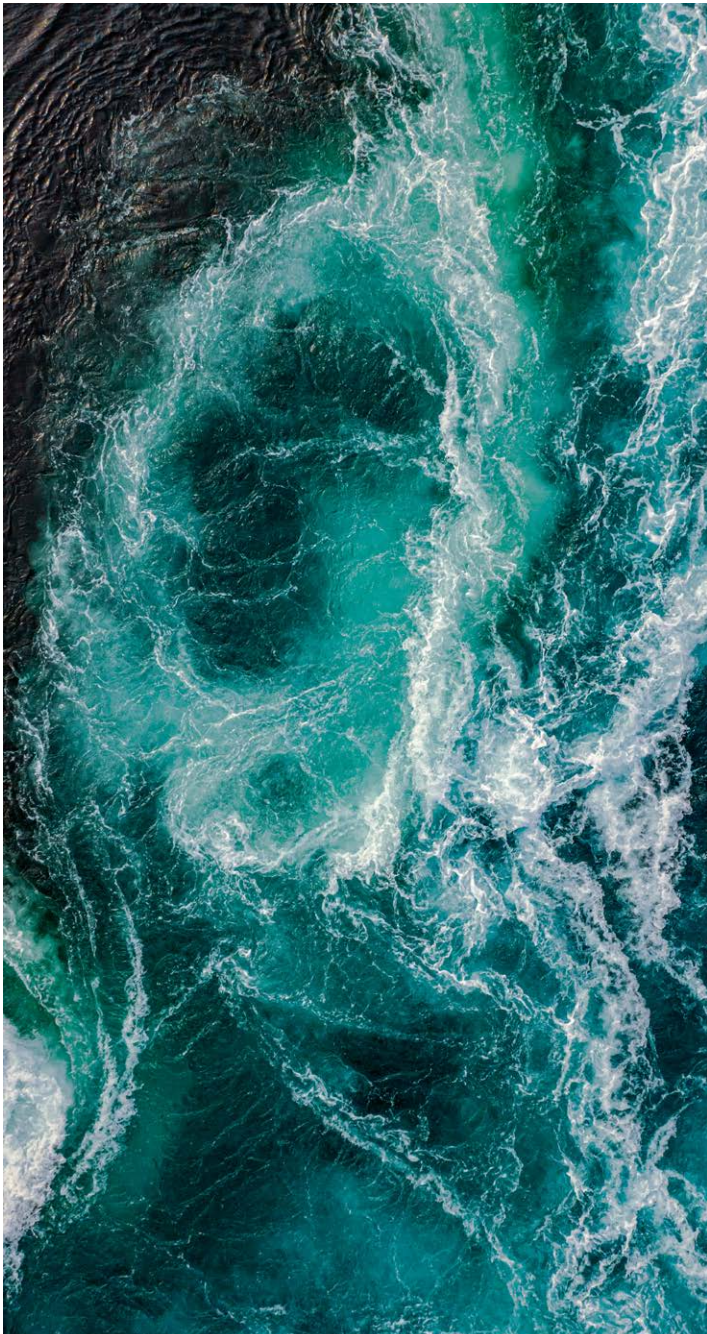



**ITALIAN PERSONALITY**

## IL SAPER FARE ITALIANO SU MISURA

Si parte sempre dal generale per scoprire il lato sottile del particolare, quello che custodisce l'arte del saper fare la differenza. Un principio che si estende anche all'interno dell'ampio mondo dell'arredo bagno, dove Newform svela il suo design sartoriale, con collezioni proprie di un carattere distintivo che rispondono alle richieste dei mercati internazionali. I prodotti si trasformano in complementi di arredo dalla forte impronta italiana, dove il processo artigianale della loro lavorazione gioca un ruolo fondamentale in termini di distinzione e qualità. Un design basato sul concetto del tailor-made, in cui non domina la generalità, ma la particolarità, la ricercatezza e l'attenzione ai dettagli, come costruito "su misura" per ogni spazio riservato alla cura di sé. Dall'estro artigiano di creare con abilità e passione manufatti per la vita quotidiana, Newform definisce il suo concept di rubinetteria sartoriale per l'ambiente bagno con linee e finiture che incontrano le evoluzioni del design. Un know-how che abbiamo maturato usando mani, testa e cuore, non solo macchine, per creare prodotti in grado di attraversare tempi e luoghi del benessere abitativo.

Quando l'abitare contemporaneo evolve senza sosta, la sfida più grande di Newform consiste nel saper crescere e mutare a ritmo delle tendenze moderne, con una proposta che superi gli standard, ma che sia portatrice del tratto artigianale del Made in Italy. Il risultato di un costante viaggio evolutivo in continuità con l'expertise del passato, grazie al quale ogni collezione porta la firma del saper fare italiano di Newform.

### MADE-TO-MEASURE ITALIAN SAVOIR-FAIRE

*You always start with the general to discover the subtle side of the detail, that which holds the art of knowing how to make a difference. A principle that also extends into the wide world of bathroom furniture, where Newform unveils its sartorial design, with collections that have a distinctive character and meet the demands of international markets. The products are transformed into furnishing accessories with a strong Italian imprint, where the artisan process of their manufacture plays a fundamental role in terms of distinction and quality. A design based on the tailor-made concept, in which generality does not dominate, but uniqueness, refinement and attention to detail, as if "tailor-made" for each space reserved for self-care. Newform defines its concept of tailor-made bathroom fittings with the craftsman's flair to create artefacts for everyday life with skill and passion, with lines and finishes that meet the evolution of design. Know-how that we have matured using our hands, head and heart and not just machines to create products capable of crossing times and places of living comfort.*

*When contemporary living evolves relentlessly, Newform's greatest challenge is to know how to grow and change at the pace of modern trends, with a proposal that exceeds standards but bears the handcrafted trait of Made in Italy. The result of a constant evolutionary journey in continuity with past expertise, thanks to which each collection bears the signature of Newform's Italian know-how.*

### LE SAVOIR-FAIRE ITALIEN SUR MESURE

*Il faut toujours partir des généralités pour découvrir l'aspect subtil du détail, celui qui renferme l'art du savoir faire la différence. Un principe qui s'étend aussi à l'intérieur du vaste monde de l'ameublement de salle de bain, où Newform dévoile son design artisanal, avec des collections au caractère distinctif qui répondent aux demandes des marchés internationaux. Les produits se transforment en compléments d'ameublement à la forte empreinte italienne, où le processus artisanal de leur traitement joue un rôle fondamental en termes de distinction et de qualité. Un design qui se base sur le concept du tailor-made, où ce n'est pas la généralité qui domine, mais la particularité, la recherche et l'attention aux détails, comme fabriqué "sur mesure" pour les espaces réservés au soin de soi. Grâce à l'inspiration artisanale de créer avec talent et passion des objets pour la vie quotidienne, Newform définit son concept de mitigeurs artisanaux pour la salle de bain avec des lignes et des finitions qui suivent les évolutions du design. Un savoir-faire que nous avons acquis en utilisant les mains, la tête et le cœur, pas uniquement des machines, afin de créer des produits en mesure de traverser les périodes et les lieux du bien-être de l'habitat.*

*Quand l'habitat contemporain évolue sans relâche, le plus grand défi de Newform consiste à savoir mûrir et évoluer au rythme des tendances modernes, avec une proposition qui dépasse les standards, mais caractérisée par la particularité artisanale du Made in Italy. Le résultat d'une transformation constante en continuité avec l'expertise du passé, qui fait que chaque collection porte la signature du savoir-faire italien de Newform.*

### PASSGENAUES ITALIENISCHES KNOW-HOW

*Man beginnt immer mit dem Allgemeinen, um die Feinheiten des Besonderen zu entdecken, also die Kunst zu wissen, wie man etwas verändern kann. Ein Prinzip, das sich auch auf die weite Welt der Badmöbel ausdehnt, wo Newform mit Kollektionen, die einen unverwechselbaren Charakter haben und den Anforderungen der internationalen Märkte entsprechen, sein künstlerisches Design vorstellt. Die Produkte verwandeln sich in Wohnaccessoires mit starker italienischer Prägung, bei denen der handwerkliche Fertigungsprozess eine Schlüsselrolle in Bezug auf Unterscheidung und Qualität spielt. Ein Design, das auf dem Konzept der Maßanfertigung basiert, bei dem nicht die Allgemeinheit dominiert, sondern das Besondere, die Raffinesse und die Liebe zum Detail, die für jeden Raum, der für die Selbstpflege reserviert ist, "maßgeschneidert" sind. Ausgehend vom Gespür des Handwerkers für die Herstellung von Gegenständen des Alltags mit Geschick und Leidenschaft, definiert Newform seine Konzeption von maßgefertigten Badarmaturen mit Linien und Oberflächen, die der Evolution des Designs entsprechen. Ein Wissen, das wir mit Händen, Verstand und Herz, nicht nur mit Maschinen, entwickelt haben, um Produkte zu schaffen, die Zeit und Raum überdauern.*

*In einer Zeit, in der sich das moderne Leben unaufhörlich weiterentwickelt, besteht die größte Herausforderung für Newform darin, mit den modernen Trends mitzuwachsen und sich zu verändern, und zwar mit einem Angebot, das über die Standards hinausgeht und dennoch den handwerklichen Charakter des Made in Italy trägt. Dies ist das Ergebnis einer ständigen Weiterentwicklung in Kontinuität mit den Erfahrungen der Vergangenheit, dank derer jede Kollektion die Handschrift des italienischen Know-hows von Newform trägt.*

### EL SABER HACER ITALIANO A MEDIDA

*Siempre se parte de lo general para descubrir el lado sutil de los detalles, que custodian el arte de saber marcar la diferencia. Un principio que se extiende también dentro del amplio mundo del equipamiento de baño, donde Newform desvela su diseño de sastrería, con colecciones propias de un carácter distintivo que responden a las demandas de los mercados internacionales. Los productos se transforman en complementos de decoración con una fuerte impronta italiana, donde el proceso artesanal de la elaboración juega un papel fundamental en términos de distinción y calidad. Un diseño basado en el concepto del tailor-made, en el que no domina la generalidad, sino la particularidad, el refinamiento y la atención al detalle, como construido "a medida" para cada espacio reservado para el cuidado personal. A partir de la inspiración artesanal de crear con habilidad y pasión productos manufacturados para la vida cotidiana, Newform define su concepto de grifería de sastrería para el baño con líneas y acabados que cumplen con las evoluciones del diseño. Un know-how que hemos madurado utilizando las manos, la cabeza y el corazón, no solo máquinas, para crear productos capaces de cruzar tiempos y lugares de bienestar en el hogar.*

*Mientras la vida contemporánea evoluciona sin cesar, el mayor desafío de Newform consiste en saber crecer y cambiar al ritmo de las tendencias modernas, con una propuesta que supere los estándares, pero que sea portadora del rasgo artesanal del Made in Italy. El resultado de un constante viaje evolutivo en continuidad con la experiencia del pasado, gracias al cual cada colección lleva consigo la firma del saber hacer italiano de Newform.*

Concentrarsi sulla creazione di uno stile personale, definito e originale, rende possibile la realizzazione di un prodotto unico, distintivo e inconfondibile. Solo attraverso il perfezionamento e il controllo di tutti i passaggi produttivi, dalle lavorazioni meccaniche ai trattamenti superficiali, dalla pulitura alla verniciatura fino all'assemblaggio, il lavoro di Newform si concretizza nella produzione di strumenti che abbracciano il concetto di design funzionale, affiancando all'aspetto visivo della materia anche l'essenza fisica e reale del benessere sensoriale.

Oggi più che mai l'azienda è orgogliosa della propria produzione Made in Italy ed è una tra le poche in grado di realizzare autonomamente tutte le fasi della produzione, dalla progettazione alla creazione del prodotto finito.

Il nostro sistema produttivo guarda al futuro, in termini di estetica, di durata del prodotto, ma soprattutto di automazione. Da diversi anni, Newform possiede un magazzino verticale automatico di tipo intensivo. La realizzazione di quest'opera ha permesso che tutti i materiali presenti in azienda venissero posti in un'unica locatione. La movimentazione del materiale avviene mediante navette computerizzate che trasportano quanto necessario in tutti i reparti produttivi.

L'innovazione e l'avanzamento tecnologico diventano quindi un supporto agli organi produttivi dell'azienda, senza sostituire la maestria e l'abilità di chi ogni giorno lavora per creare qualcosa di unico e sorprendente al tempo stesso.

*Focusing on the creation of a personal, defined and original style makes it possible to create a unique, distinctive and unmistakable product. It is only by perfecting and controlling all the production stages, from mechanical machining to surface treatments, from cleaning to painting and assembly, that Newform's work is reflected in the production of instruments that embrace the concept of functional design, combining the visual aspect of the material with the physical and real essence of sensory well-being.*

*Today, more than ever, the company is proud of its Made in Italy production and is one of the few able to carry out all stages of production independently, from design to the finished product. Our production system looks to the future, in terms of aesthetics, product durability, and above all automation. For several years, Newform has had an automated vertical warehouse. This has enabled all materials in the company to be placed in a single location. Material handling is done using computerised shuttles that transport what is needed to all production departments. Innovation and technological advancement thus become a support for the company's production organs, without replacing the craftsmanship and skill of those who work every day to create something unique and at the same time surprising.*

*Se concentrer sur la création d'un style personnel, défini et original, permet la réalisation d'un produit unique et distinctif. Ce n'est qu'à travers le perfectionnement et le contrôle de tous les passages de production, des traitements mécaniques aux traitements de surface, du nettoyage à la peinture jusqu'à l'assemblage, que le travail de Newform se concrétise dans la production d'instruments qui embrassent le concept de design fonctionnel, pour juxtaposer à l'aspect visuel de la matière également l'essence physique et réelle du bien-être sensoriel.*

*Aujourd'hui plus que jamais, l'entreprise est fière de sa production Made in Italy et elle reste une des rares en mesure de réaliser toutes les phases de la production en totale autonomie, de la conception à la réalisation du produit fini. Notre système de production est tourné vers l'avenir, en termes d'esthétique, de durée du produit, mais surtout d'automatisation. Depuis plusieurs années, Newform possède un entrepôt à hauts rayonnages automatique de type intensif. La réalisation de cet ouvrage a permis de ranger tout le matériel présent dans l'entreprise dans un lieu unique. La manutention du matériel se fait avec des navettes informatisées qui transportent les produits nécessaires vers tous les services de production. L'innovation et l'avancée technologique deviennent donc un support aux organes de production de l'entreprise, sans pour autant remplacer la maîtrise et le talent de qui, chaque jour, travaille pour créer quelque chose à la fois d'unique et de surprenant.*

*Die Fokussierung auf einen persönlichen, definierten und originellen Stil macht es möglich, ein einzigartiges, unverwechselbares Produkt zu kreieren. Nur durch die Perfektionierung und Kontrolle aller Produktionsschritte, von der Bearbeitung bis zur Oberflächenbehandlung, von der Reinigung bis zur Lackierung und Montage, wird die Arbeit von Newform in der Produktion von Instrumenten umgesetzt, die das Konzept des funktionalen Designs umfassen und den visuellen Aspekt des Materials mit der realen, physischen Essenz des sensorischen Wohlbefindens verbinden.*

*Mehr denn je ist das Unternehmen heute stolz auf seine 'Made in Italy'-Produktion und gehört zu den wenigen, die alle Herstellungsschritte, vom Design bis zum fertigen Produkt, selbständig durchführen können. Unser Produktionssystem ist zukunftsorientiert, was die Ästhetik, die Haltbarkeit der Produkte, aber vor allem die Automatisierung angeht. Seit einigen Jahren verfügt Newform über ein intensives automatisches vertikales Lager. Die Umsetzung dieser Arbeit ermöglichte es, alle Materialien im Unternehmen an einem Ort zu platzieren. Der Materialumschlag erfolgt über computergesteuerte Shuttles, die das benötigte Material zu allen Produktionsabteilungen transportieren. Innovation und technologischer Fortschritt werden so zu einer Stütze für die Produktionsorgane des Unternehmens, ohne das handwerkliche Können derjenigen zu ersetzen, die jeden Tag daran arbeiten, etwas Einzigartiges und zugleich Überraschendes zu schaffen.*

*Centrarse en la creación de un estilo personal, definido y original, hace posible la realización de un producto único, distintivo e inconfundible. Solo a través del perfeccionamiento y el control de todos los pasos de producción, desde el procesamiento mecánico hasta los tratamientos superficiales, desde la limpieza hasta la pintura y el ensamblaje, el trabajo de Newform se concreta en la producción de instrumentos que abrazan el concepto de diseño funcional, combinando el aspecto visual de la materia con la esencia física y real del bienestar sensorial.*

*Hoy más que nunca, la empresa está orgullosa de su producción Made in Italy y es una de las pocas capaces de realizar de forma autónoma todas las fases de la producción, desde el diseño hasta la creación del producto terminado. Nuestro sistema de producción mira hacia el futuro, en términos de estética, durabilidad del producto y, sobre todo, de automatización. Desde hace varios años, Newform dispone de un almacén vertical automático de tipo intensivo. La realización de esta obra ha permitido que todos los materiales presentes en la empresa se dispongan en una única ubicación. El movimiento del material se realiza mediante lanzaderas informatizadas que transportan lo necesario a todos los departamentos de producción. De esta forma, la innovación y el avance tecnológico se convierten en un apoyo para los elementos productivos de la empresa, sin sustituir la maestría y la habilidad de las personas que trabajan cada día para crear algo único y sorprendente al mismo tiempo.*



GUARDA IL VIDEO  
WATCH THE VIDEO  
REGARDEZ LA VIDÉO  
SCHAUEN SIE SICH DAS VIDEO AN  
VER EL VÍDEO

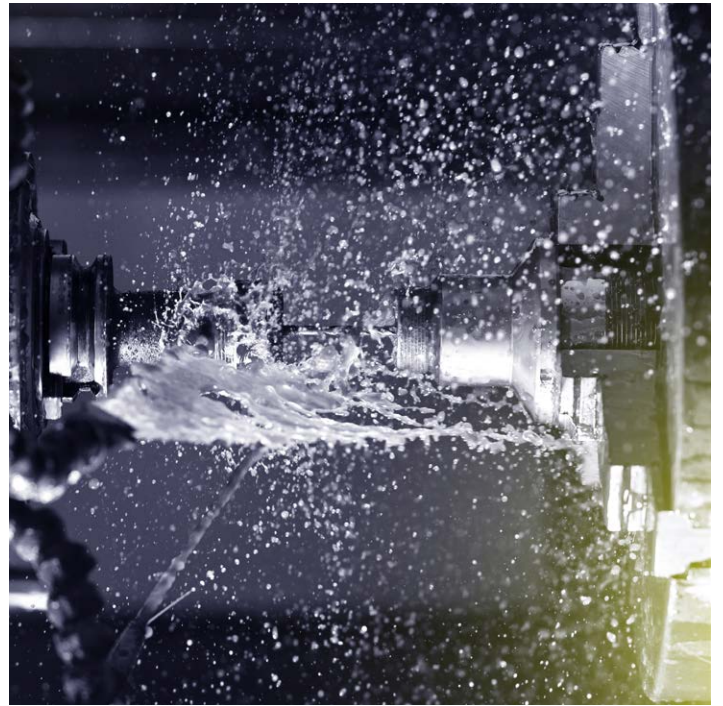
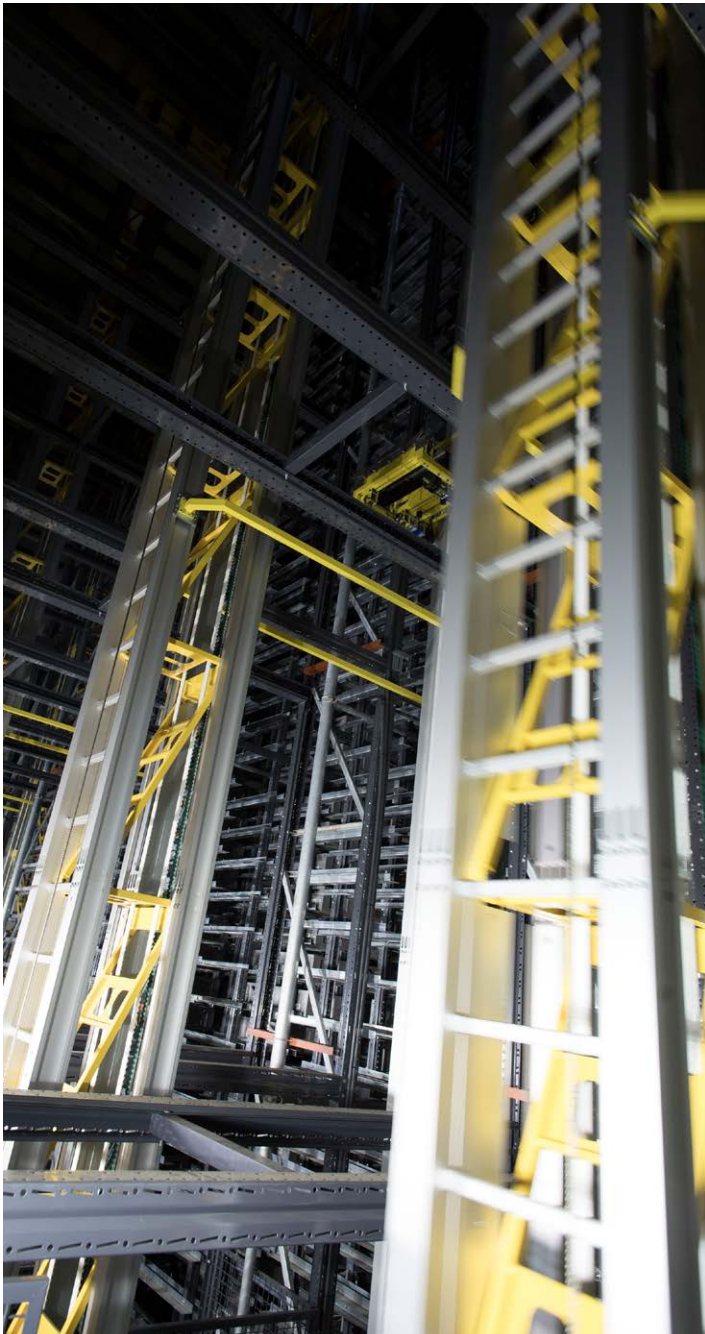
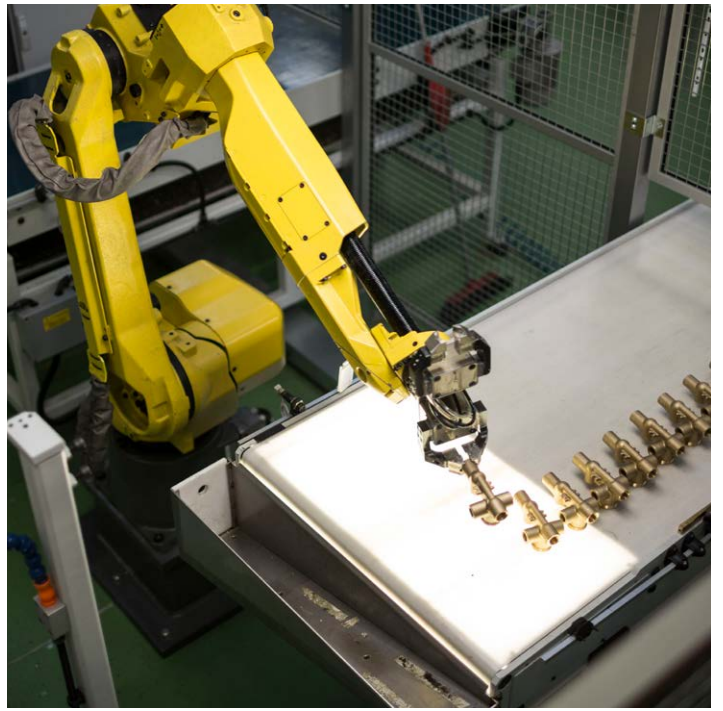

The background is a dark blue field filled with a complex, glowing network of thin, light blue lines. These lines form a dense, interconnected web that flows and curves across the frame, creating a sense of dynamic movement and depth. Scattered throughout the network are numerous small, bright blue and white particles, some appearing as sharp points of light and others as soft, out-of-focus bokeh. The overall effect is that of a futuristic, digital or neural network, with a cool, high-tech aesthetic.

**INNOVATION**

## INNOVAZIONE CREATIVA E MATERICA

L'intuizione creativa è la chiave di un linguaggio di design che parla di innovazione di luoghi, processi e persone, oltre che di prodotti. Innovare significa creare nuove forme di benessere e costituisce lo stimolo vitale che alimenta da sempre la ricerca di Newform, il fulcro attorno a cui ruota il successo dell'azienda. Il design come fondamento del prodotto, i materiali più raffinati e la tecnologia attenta all'ambiente, creano un prodotto originale e di qualità, ricercato e concreto. Quando l'innovazione è il principio di ogni idea, la ricerca diventa fondamentale per mettere in scena il proprio concetto di una nuova bellezza degli spazi del vivere quotidiano.

L'estetica e la materia sono requisiti fondamentali del prodotto, così come la cura e l'attenzione per i particolari e per le proporzioni sono gli aspetti che fanno la differenza. In un gioco di forme, colori e finiture, Newform firma i suoi prodotti studiando profili e linee che incontrano le tendenze del design contemporaneo, scegliendo materiali dalle alte performance qualitative, resistenti e durevoli, completati da finiture ispirate ai trend cromatici.

La continua innovazione creativa e materica è il punto di arrivo di una proposta infinitamente personalizzabile e dall'inesauribile creatività, capace di arredare gli ambienti con sfumature che enfatizzano il design del prodotto ed esaltano le qualità estetiche dei materiali.

### CREATIVE AND MATERIAL INNOVATION

*Creative intuition is the key to a design language that talks about the innovation of places, processes and people, as well as products. Innovation means creating new forms of well-being and is the vital stimulus that has always driven Newform's research, the fulcrum around which the company's success revolves. Design as the foundation of the product, the finest materials and environmentally friendly technology create an original, quality product that is both refined and practical. When innovation is the principle of every idea, research becomes fundamental to staging one's own concept of a new beauty of everyday living spaces.*

*Aesthetics and material are fundamental product requirements, just as care and attention to detail and proportions are the aspects that make the difference. In an interplay of shapes, colours and finishes, Newform designs its products by studying profiles and lines that meet the trends of contemporary design, choosing materials with high-quality, resistant and durable performance, complemented by finishes inspired by colour trends.*

*The continuous creative and material innovation is the point of arrival of an endlessly customisable proposal with inexhaustible creativity, capable of furnishing rooms with nuances that emphasise the design of the product and enhance the aesthetic qualities of the materials.*

### INNOVATION DE LA CRÉATION ET DE LA MATIÈRE

*L'intuition créative est la clé d'un langage de design qui parle d'innovation de lieux, processus et personnes, en plus que de produits. Innover signifie créer de nouvelles formes de bien-être et c'est la stimulation vitale qui alimente depuis toujours la recherche de Newform, l'élément clé à la base de la réussite de l'entreprise. Le design comme fondement du produit, les matériaux plus raffinés et la technologie attentive à l'environnement créent un produit original et de qualité, recherché et concret. Quand l'innovation est à la base de chaque idée, la recherche devient fondamentale pour mettre en scène son concept d'une nouvelle beauté des espaces de la vie quotidienne.*

*L'esthétique et la matière sont les exigences de base du produit, tout comme le soin et l'attention aux détails et aux proportions sont les aspects qui font la différence. Dans un jeu de formes, de couleurs et de finitions, Newform signe ses produits en étudiant des profils et des lignes qui répondent aux tendances du design contemporain, en choisissant des matériaux ayant des performances qualitatives supérieures, résistantes et durables, avec des finitions qui s'inspirent de continues tendances chromatiques.*

*La constante innovation de la création et de la matière est l'aboutissement d'une proposition qui peut être personnalisée à l'infini et à la créativité inépuisable, en mesure de meubler les espaces avec des nuances qui soulignent le design du produit et exaltent les qualités esthétiques des matériaux.*

### KREATIVE UND MATERIELLE INNOVATION

*Schöpferische Intuition ist der Schlüssel zu einer Design-Sprache, die von der Innovation von Orten, Prozessen und Menschen ebenso wie von Produkten spricht. Innovation bedeutet, neue Formen des Wohlbefindens zu schaffen und ist der entscheidende Impuls, der die Forschung von Newform seit jeher antreibt, der Dreh- und Angelpunkt, um den sich der Erfolg des Unternehmens dreht. Design als Grundlage des Produkts, die besten Materialien und umweltbewusste Technologie schaffen ein originelles, hochwertiges Produkt, das sowohl anspruchsvoll als auch praktisch ist. Wenn die Innovation das Prinzip einer jeden Idee ist, wird die Forschung unerlässlich, um das eigene Konzept einer neuen Schönheit der täglichen Lebensräume zu verwirklichen.*

*Ästhetik und Material sind grundlegende Anforderungen an das Produkt, genauso wie Sorgfalt und Liebe zum Detail und zu den Proportionen die Aspekte sind, die den Unterschied ausmachen. In einem Zusammenspiel von Formen, Farben und Oberflächen zeichnet Newform seine Produkte durch die Untersuchung von Profilen und Linien aus, die den Trends des zeitgenössischen Designs entsprechen, und wählt dafür hochwertige, widerstandsfähige und langlebige Materialien, die durch Oberflächenbehandlungen ergänzt werden, die von den aktuellen Farbtrends inspiriert sind.*

*Die ständige kreative und materielle Innovation ist der Ansatzpunkt für ein unendlich anpassbares Angebot mit unerschöpflicher Kreativität, das in der Lage ist, Räume mit Akzenten einzurichten, die das Design des Produkts betonen und die ästhetischen Qualitäten der Materialien hervorheben.*

### INNOVACIÓN CREATIVA Y DE MATERIALES

*La intuición creativa es la clave de un lenguaje de diseño que habla de la innovación de lugares, procesos y personas, así como de productos. Innovar significa crear nuevas formas de bienestar y constituye el estímulo vital que alimenta desde siempre la investigación de Newform, el eje en torno al cual gira el éxito de la empresa. El diseño como base del producto, los materiales más refinados y la tecnología respetuosa con el medio ambiente crean un producto original y de calidad, refinado y concreto. Cuando la innovación es el principio de toda idea, la investigación se vuelve fundamental para escenificar el propio concepto de una nueva belleza de los espacios de la vida cotidiana.*

*La estética y la materia son requisitos fundamentales del producto, del mismo modo que el cuidado y la atención por los detalles y las proporciones son los aspectos que marcan la diferencia. En un juego de formas, colores y acabados, Newform firma sus productos estudiando perfiles y líneas que se encuentran con las tendencias del diseño contemporáneo, seleccionando materiales de alto rendimiento cualitativo, resistentes y duraderos, complementados con acabados inspirados en las tendencias cromáticas.*

*La continua innovación creativa y de materiales es el punto de llegada de una propuesta infinitamente personalizable y de creatividad inagotable, capaz de vestir los espacios con matices que enfatizan el diseño del producto y resaltan las cualidades estéticas de los materiales.*

●

Design ispirato al miglior "Made in Italy", tecnologia in sintonia con le esigenze ambientali, standard qualitativi e certificazioni internazionali, sono le ragioni che hanno permesso a Newform di essere protagonista nel mercato mondiale.

Costruire relazioni commerciali importanti oltre i confini nazionali non solo richiede una consolidata rete di partners, ma impone il conseguimento di specifiche certificazioni riconosciute dai Paesi in cui nel corso degli anni è stato introdotto il design Newform. Una misura che considera la sicurezza del prodotto e del suo utilizzo durante la vita quotidiana come condizione di primaria importanza per il suo commercio. Crediamo nel valore di ciò che ogni giorno produciamo ed è nostro reale interesse che venga riconosciuta l'osservanza di Newform agli standard imposti in fatto di qualità e sicurezza.

●

*Design inspired by the best "Made in Italy", technology in tune with environmental requirements, quality standards and international certifications are the reasons that have allowed Newform to be a leading player in the global market.*

*Building important business relationships beyond national borders not only requires a well-established network of partners but also requires the achievement of specific certifications recognised by the countries where Newform design has been introduced over the years. A measure that considers the safety of the product and its use during daily life as a condition of primary importance for its trade. We believe in the value of what we produce every day, and it is in our real interest that Newform's compliance with the imposed standards of quality and safety be recognised.*

●

*Design, inspiriert vom besten "Made in Italy", Innovation und Technologie im Einklang mit Umweltauforderungen, Qualitätsstandards und internationalen Zertifizierungen sind die Gründe, warum Newform ein führender Akteur auf dem Weltmarkt geworden ist.*

*Um wichtige Geschäftsbeziehungen über die Landesgrenzen hinaus aufzubauen, ist nicht nur ein gut etabliertes Partnernetzwerk erforderlich, sondern auch die Erlangung spezifischer Zertifizierungen, die von den Ländern, in denen das Newform Design im Laufe der Jahre eingeführt wurde, anerkannt werden. Eine Maßnahme, die die Sicherheit des Produkts und seine Verwendung im Alltag als Hauptvoraussetzung für den Handel betrachtet. Wir sind überzeugt vom Wert dessen, was wir jeden Tag produzieren, und es liegt in unserem ureigenen Interesse, dass die Einhaltung der auferlegten Qualitäts- und Sicherheitsstandards durch Newform anerkannt wird.*

●

*Design qui s'inspire du meilleur "Made in Italy", innovation et technologie en harmonie avec les exigences des espaces, standards qualitatifs et certifications internationales sont les éléments qui ont permis à Newform d'être protagoniste sur le marché mondial.*

*Établir d'importantes relations commerciales au-delà des frontières n'implique pas juste un réseau bien établi de partenaires, mais aussi l'obtention de certifications spécifiques reconnues par les pays où le design Newform s'est établi avec les années. Une mesure qui voit la sécurité du produit et de son utilisation durant la vie de tous les jours comme une condition primordiale pour son commerce. Nous croyons dans la valeur de ce que nous produisons chaque jour et ce que nous voulons avant tout, c'est que le respect de Newform à l'égard des standards imposés en termes de qualité et de sécurité soit reconnu.*

●

*Diseño inspirado en el mejor "Made in Italy", tecnología en sintonía con las exigencias medioambientales, estándares de calidad y certificaciones internacionales, son las razones que han permitido a Newform ser protagonista en el mercado mundial.*

*Construir relaciones comerciales importantes más allá de las fronteras nacionales no solo requiere una red consolidada de socios, sino que también exige la obtención de certificaciones específicas reconocidas por los países en los que se ha introducido el diseño Newform a lo largo de los años. Una medida que considera la seguridad del producto y su uso durante la vida diaria como una condición primordial para su comercialización. Creemos en el valor de lo que producimos cada día y es nuestro verdadero interés que se reconozca el cumplimiento de Newform de los estándares impuestos en materia de calidad y seguridad.*



GUARDA IL VIDEO  
WATCH THE VIDEO  
REGARDEZ LA VIDÉO  
SCHAUEN SIE SICH DAS VIDEO AN  
VER EL VÍDEO



# MADE IN ITALY

## SYSTEM CERTIFICATIONS

---



## PRODUCT CERTIFICATIONS

---







## NEWFORM FINISHES

Newform offre un'ampia gamma di finiture per impreziosire gli ambienti e renderli unici. I trattamenti galvanici e quelli verniciati danno la possibilità di arredare gli spazi giocando con le cromie. I trattamenti galvanici sono procedimenti estetici e protettivi, che si ottengono tramite deposizioni elettrochimiche di uno strato sottile di un metallo o di una lega su una superficie. Conferiscono al prodotto resistenza alla corrosione e durezza nel tempo. Procedimenti estetici e protettivi. Le finiture bianco e nero matt invece sono effetti estetici che vanno a complemento delle finiture Newform. Colori opachi e di grande tendenza, colori adatti a chi è amante dell'esclusività e dell'unicità.

Newform offers a wide range of finishes to embellish and make your bathroom unique. Galvanic and painted treatments allow you to furnish and play with colours. Galvanic treatments are aesthetic and protective procedures. They consist of electrochemical depositions of a thin layer of metal or alloy on the surface. This treatment ensures corrosion resistance and durability over time. Aesthetic and protective procedures. Matt black and white finishes, on the other hand, are aesthetic effects that complete the Newform finish range. Matt and trendy colours, perfect for those who love exclusivity and uniqueness.

Newform propose une vaste gamme de finitions pour embellir les espaces et les rendre uniques. Les traitements galvaniques et ceux peints permettent de décorer les espaces en jouant avec les couleurs. Les traitements galvaniques sont des procédés esthétiques et de protection obtenus grâce à des dépôts électrochimiques d'une fine couche de métal ou d'alliage sur une surface. Ils rendent le produit résistant à la corrosion et durable dans le temps. Des procédés esthétiques et de protection. En revanche, les finitions noir et blanc mat sont des effets esthétiques qui complètent les finitions Newform. Des couleurs opaques et très tendance, des couleurs adaptées pour qui aime l'exclusivité et la singularité.

Newform bietet eine große Auswahl an Ausführungen, um Umgebungen zu verschönern und sie einzigartig zu machen. Galvanische und lackierte Behandlungen geben die Möglichkeit, Räume durch das Spiel mit Farben einzurichten. Galvanische Behandlungen sind ästhetische und schützende Verfahren, die durch elektrochemische Abscheidung einer dünnen Schicht eines Metalls oder einer Legierung auf einer Oberfläche erhalten werden. Sie verleihen dem Produkt Korrosionsbeständigkeit und Haltbarkeit im Laufe der Zeit. Ästhetische und schützende Verfahren. Die Ausführungen in mattem Schwarz und Weiß hingegen sind ästhetische Effekte, die die Newform-Ausführungen ergänzen. Deckende und trendige Farben, Farben, die für diejenigen geeignet sind, die Exklusivität und Einzigartigkeit lieben.

Newform ofrece una amplia gama de acabados para embellecer los ambientes y valerlos únicos. Los tratamientos galvanicos y pintados ofrecen la posibilidad de decorar los espacios jugando con los colores. Los tratamientos galvanicos son procedimientos estéticos y protectores que se obtienen mediante la formación electroquímica de una fina capa de un metal o una aleación sobre una superficie. Aportan al producto resistencia a la corrosión y durabilidad a lo largo del tiempo. Procedimientos estéticos y de protección. Por su parte, los acabados en blanco y negro mate son efectos estéticos que complementan los acabados de Newform. Colores mate y de gran tendencia, ideales para los amantes de la exclusividad y la singularidad.

●

PVD (Physical Vapor Deposition)  
Trattamento ottenuto dalla deposizione di film sottili sottovuoto. Rivestimento pregiato e durevole nel tempo, ha diverse qualità che lo rendono un importante valore aggiunto al prodotto: ha un'alta attività di abbattimento della carica batterica che rende la sua superficie igienica e facile da pulire, inoltre è resistente alle abrasioni e soprattutto assicura una inalterabilità delle tonalità.

●

*PVD (Physical Vapor Deposition)  
It is a treatment based on the vacuum deposition of thin films. It is a refined and durable coating. Its outstanding features represent true plus-points for the product: it significantly reduces the bacterial load, making its surface hygienic and easy to clean. It is also abrasion-resistant and ensures unalterable colours.*

●

PVD (Physical Vapor Deposition)  
Traitement obtenu à partir du dépôt de minces films sous vide. Revêtement précieux et durable dans le temps, il a différentes qualités qui font qu'il apporte une grande valeur ajoutée au produit : il permet aussi de réduire de la charge bactérienne, ce qui en fait une surface hygiénique et facile à nettoyer. Par ailleurs, il est résistant aux abrasions et surtout, il assure une inaltérabilité des teintes.

●

*PVD (Physical Vapor Deposition)  
Behandlung, die durch Abscheidung dünner Schichten im Vakuum erreicht wird. Es handelt sich um eine hochwertige und langlebige Beschichtung, die mehrere Eigenschaften aufweist, die einen wichtigen Mehrwert für das Produkt darstellen: Sie hat eine hohe Keimreduzierungsaktivität, die ihre Oberfläche hygienisch und leicht zu reinigen macht, sie ist außerdem abriebfest und gewährleistet vor allem Farbechtheit.*

●

PVD (Physical Vapor Deposition)  
Tratamiento obtenido a partir de la deposición al vacío de películas finas. Es un revestimiento apreciado y duradero que presenta varias cualidades que lo convierten en un importante valor añadido para el producto: tiene una alta actividad de reducción de la carga bacteriana que hace que su superficie sea higiénica y fácil de limpiar, además es resistente a las abrasiones y, sobre todo, garantiza la inalterabilidad de los tonos.

## PVD



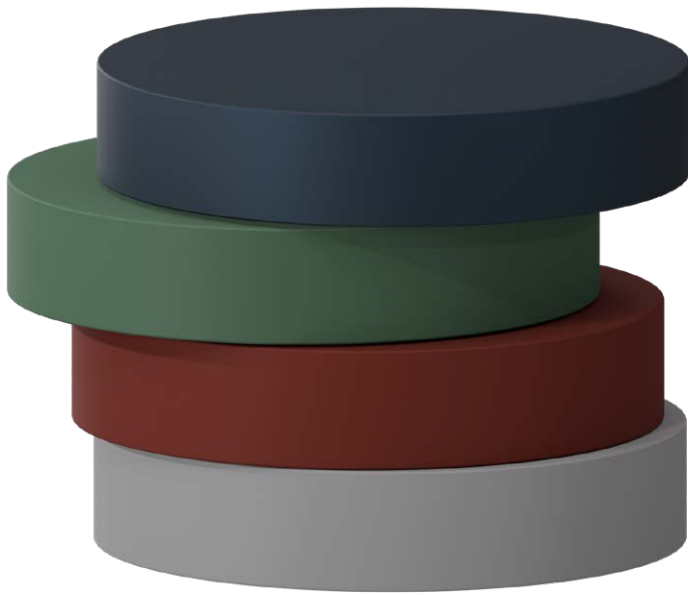

## SOFT COLOR

Un ventaglio di finiture opache che incuriosisce per la tattilità della superficie e per l'originalità delle tre cromie presentate che richiamano i trend in corso dell'arredo cucina. Trattasi di un sottile strato di vernice a polvere dalla setosità tattile e materica e dall'effetto matt, con una bassa riflessione della luce. Le colorazioni prendono ispirazione dalle principali sfumature presenti in natura e permettono alla rubinetteria di identificarsi come il ricercato accento di colore nell'ambiente cucina moderno.

A range of matt finishes that is intriguing for the tactility of their surfaces and for the originality of the three on-trend kitchen furnishing colours. The coating consist of a thin layer of powder paint, giving it a tactile and material silkiness and matt effect, with low reflectivity. The colours take their inspiration from natural tones, allowing taps, faucets and fittings to stand out as highly sought-after colour accents in the modern kitchen environment.

Une palette de finitions opaques qui éveille la curiosité pour la tactilité de la surface et pour l'originalité des trois couleurs présentes qui rappellent les tendances actuelles de l'ameublement cuisine. Il s'agit d'une fine couche de peinture à poudre au toucher soyeux et textural et à l'effet mat, avec un reflet réduit de la lumière. Les colorations s'inspirent des principales nuances présentes dans la nature et permettent aux robinets de s'identifier comme l'accent recherché de couleur dans l'espace cuisine moderne.

Ein Angebot an matten Oberflächen, die durch die Fühlbarkeit der Oberfläche und die Einzigartigkeit der drei vorgestellten Farben fasziniert, die an die aktuellen Trends bei Küchenmöbeln erinnern. Es handelt sich um eine dünne Pulverbeschichtung, die eine seidige Fühlbarkeit und Textur sowie einen matten Effekt mit geringer Lichtreflexion aufweist. Die Farben orientieren sich an den Haupttönen der Natur und lassen die Küchenarmaturen zu einem begehrten Farbakzent in der modernen Küche werden.

Un abanico de acabados mate que intriga por la tactilidad de la superficie y por la originalidad de los tres colores presentes que recuerdan las tendencias actuales de la decoración en cocina. Se trata de una fina capa de pintura en polvo con sedosidad táctil y material, y efecto mate, con una baja reflexión de la luz. Los colores se inspiran en los principales matices presentes en la naturaleza y logran que la grifería se identifique como la refinado nota de color en el entorno de la cocina moderna.



●  
Finitura innovativa che coniuga raffinate soluzioni estetiche con prestazioni tecnologiche all'avanguardia. Con una bassa riflessione della luce, la sua superficie è satinata e anti-impronte digitali. La gamma include una proposta di preziosi colori metallescenti dai riverberi cromatici di sicuro effetto su una superficie supermatt e una selezione esclusiva di espressioni materiche.

●  
*Innovative finish that combines elegant aesthetic solutions with state-of-the-art technological performance. Its surface, with low light reflection, is satin and anti-fingerprint. The range includes a choice of precious colours with metal effects, a superb effect on a super matt surface, and an exclusive selection of tactile perceptions.*

●  
Finition innovante qui combine solutions esthétiques raffinées et performances technologiques à l'avant-garde. Avec une réflexion réduite de la lumière, sa surface est satinée et anti-traces de doigts. La gamme comprend une proposition de précieuses couleurs métallisées aux reflets chromatiques qui donnent beaucoup d'effet sur une surface super mate et une sélection exclusive d'expressions texturales.

●  
*Innovative Ausführung, die raffinierte ästhetische Lösungen mit modernster technologischer Leistung kombiniert. Die Oberfläche mit geringer Lichtreflexion ist satiniert und verhindert Fingerabdrücke. Die Palette umfasst ein Angebot an edlen metallisch schimmernden Farben mit auffälligen Farbreflexen auf einer supermatten Oberfläche und eine exklusive Auswahl an Materialien.*

●  
Acabado innovador que combina refinadas soluciones estéticas con prestaciones tecnológicas de vanguardia. Con una baja reflexión de la luz, su superficie es satinada y repele las huellas dactilares. La gama incluye una propuesta de preciosos colores metalizados con reverberaciones cromáticas de gran efecto sobre una superficie supermate y una selección exclusiva de expresiones en materiales.



**EXCLUSIVE  
METAL**

# ACCIAIO INOX



● La bellezza inossidabile dell'acciaio, materiale nobile dalle proprietà impareggiabili, soddisfa standard qualitativi elevati grazie alla sua durevolezza, inalterabilità, igiene ed eco-compatibilità. La completa realizzazione in acciaio conferisce ai prodotti proprietà fondamentali, come ad esempio la resistenza, nonché una prestante predisposizione alla sostenibilità.

● *The stainless beauty of steel, a noble material with unparalleled properties, meets high-quality standards thanks to its durability, immutability, hygiene and eco-friendliness. The whole construction in stainless steel bestows the series straightforward properties, such as durability, as well as a powerful sustainability.*

● *La beauté inoxydable de l'acier, matériau noble aux propriétés incomparables, répond à des standards de qualité élevés grâce à sa dureté, à son inaltérabilité, à son hygiène et à son éco-durabilité. L'entière réalisation en acier confère aux produits des propriétés fondamentales, comme la résistance, ainsi qu'une bonne prédisposition à la durabilité.*

● *Die rostfreie Schönheit des Stahls, ein edles Material mit unübertroffenen Eigenschaften, erfüllt dank seiner Haltbarkeit, Unveränderlichkeit, Hygiene und Umweltfreundlichkeit hohe Qualitätsstandards. Die komplette Konstruktion aus Stahl verleiht den Produkten grundlegende Eigenschaften wie Widerstandsfähigkeit sowie eine Vorbereitung für Nachhaltigkeit.*

● *La belleza inoxidable del acero, un material noble de propiedades incomparables, cumple con altos estándares de calidad gracias a su durabilidad, inalterabilidad, higiene y compatibilidad ecológica. La construcción completamente en acero confiere a los productos propiedades fundamentales, como la resistencia, además de una excelente predisposición a la sostenibilidad.*

**STAINLESS STEEL**

## ● ACCIAIO INOX

Si scrive acciaio, si legge durevolezza, resistenza e, soprattutto, inossidabilità. Un materiale versatile, inalterabile nel tempo e altamente resistente a corrosione, urti e graffi, rivelandosi più che idoneo per la rubinetteria di alta gamma firmata Newform. La superficie non porosa dell'acciaio impedisce ogni eventuale accumulo di batteri e altri contaminanti, rendendolo così un materiale sicuro per gli ambienti bagno e cucina. Qui, dove gli standard sono elevati ed igiene e sostenibilità sono fondamentali dell'operare quotidiano, l'acciaio diventa la materia playmaker di serie ad alte performance qualitative.

Newform utilizza acciaio INOX per dare vita a collezioni cucina, bagno e outdoor che l'Azienda progetta e realizza nel segno della massima garanzia di qualità e sicurezza, per noi e per l'ambiente che ci circonda. Riciclabile all'infinito, questo materiale è apprezzato per essere una risorsa che non perde di qualità dopo il suo riciclo, ed è quindi riutilizzabile per produrre nuovi articoli. Riciclare l'acciaio significa ridurre le emissioni di CO<sub>2</sub> derivanti dalla produzione di nuova materia e scegliere definitivamente la via della sostenibilità.

### ● STAINLESS STEEL

*It is spelled steel, and it stands for durability, hardness, and, above all, rust-resistance.*

*A versatile material, unaltered over time and highly resistant to corrosion, shocks, and scratches, proving more than suitable for high-end faucets signed by Newform. The non-porous surface of steel prevents any potential accumulation of bacteria and other contaminants, making it a safe material for bathroom and kitchen environments. Here, where standards are high and hygiene and sustainability are fundamental to daily operations, steel becomes the protagonist for high-performance series.*

Newform uses STAINLESS steel to create kitchen, bathroom, and outdoor collections, which the company designs and manufactures with the highest guarantee of quality and safety, for both us and the environment around us. Recyclable endlessly, this material is valued for being a resource that does not lose its quality after recycling, making it reusable to produce new items. Recycling steel means reducing CO<sub>2</sub> emissions from the production of new material and choosing the path of sustainability.

### ● ACIER INOX

*On écrit acier, on lit durabilité, résistance et, surtout, inoxydabilité.*

*Un matériau polyvalent, inaltérable dans le temps et hautement résistant à la corrosion, aux chocs et aux rayures, se révélant plus qu'adapté à la robinetterie haut de gamme signée Newform. La surface non poreuse de l'acier empêche l'accumulation de bactéries et autres contaminants, le rendant ainsi un matériau sûr pour les environnements de salle de bain et de cuisine. Ici, où les normes sont élevées et où l'hygiène et la durabilité sont les bases du travail quotidien, l'acier devient le protagoniste de séries aux performances qualitatives élevées.*

Newform utilise de l'acier INOX pour créer des collections de cuisines, salles de bains et outdoor que l'entreprise conçoit et fabrique dans le respect de la garantie maximale de qualité et de sécurité, pour nous et pour l'environnement qui nous entoure. Recyclable à l'infini, ce matériau est apprécié pour être une ressource qui ne perd pas de sa qualité après recyclage, et peut donc être réutilisé pour fabriquer de nouveaux articles. Recycler l'acier signifie réduire les émissions de CO<sub>2</sub> provenant de la production de nouvelles matières premières et choisir définitivement la voie de la durabilité.



### ● EDELSTAHL

*Es ist Stahl geschrieben, es steht für Haltbarkeit, Widerstandsfähigkeit und vor allem für Rostfreiheit.*

*Ein vielseitiges Material, das im Laufe der Zeit unveränderlich und sehr widerstandsfähig gegen Korrosion, Stöße und Kratzer ist und sich für die High-End-Armaturen von Newform mehr als geeignet erweist. Die porenfreie Oberfläche des Stahls verhindert die Ansammlung von Bakterien und anderen Verunreinigungen und macht ihn zu einem sicheren Material für Bad und Küche. Hier, wo hohe Standards gelten und Hygiene und Nachhaltigkeit die Grundlagen der täglichen Arbeit sind, wird Stahl zum Spielermacher-Standardmaterial mit hoher Qualitätsleistung.*

Newform verwendet den EDELSTAHL für die Herstellung von Küchen-, Bad- und Outdoor-Kollektionen, die das Unternehmen im Namen maximaler Qualität und Sicherheit für uns und für die Umwelt, die uns umgibt, entwirft und herstellt. Dieses unendlich recycelbare Material wird als Ressource geschätzt, die nach dem Recycling nicht an Qualität verliert und daher für die Herstellung neuer Artikel wiederverwendbar ist. Stahl zu recyceln bedeutet, die CO<sub>2</sub>-Emissionen bei der Herstellung neuer Materialien zu reduzieren und sich endgültig für den Weg der Nachhaltigkeit zu entscheiden.

### ● ACERO INOXIDABLE

*Se escribe acero, se lee durabilidad, resistencia y, sobre todo, inoxidabilidad.*

*Un material versátil, inalterable con el paso del tiempo y altamente resistente a la corrosión, los golpes y los arañazos, resultando más que adecuado para la grifería de alta gama firmada por Newform. La superficie no porosa del acero impide el posible acumulamiento de bacterias y otros contaminantes, haciéndolo así un material seguro para los ambientes de baño y cocina. Aquí, donde los estándares son altos y la higiene y sostenibilidad son principios fundamentales en la labor diaria, el acero se convierte en la materia prima clave para obtener altos rendimientos cualitativos.*

Newform utiliza acero INOXIDABLE para dar vida a colecciones de cocina, baño y exteriores que la empresa diseña y realiza bajo el signo de la máxima garantía de calidad y seguridad, para nosotros y para el entorno que nos rodea. Reciclable infinitamente, este material es apreciado por ser un recurso que no pierde calidad después de su reciclaje, por lo que puede reutilizarse para producir nuevos artículos. Reciclar el acero significa reducir las emisiones de CO<sub>2</sub> derivadas de la producción de nuevo material y optar definitivamente por el camino de la sostenibilidad.



## OTTONE

Lavorare la materia prima è un'arte ereditata dagli artigiani del passato: richiede maestria e una profonda conoscenza dei materiali, anche oggi dove l'innovazione e la tecnologia sono parte integrante del ciclo produttivo. Un'accurata selezione della materia prima di alta qualità riflette l'impegno di Newform nel coniugare eccellenza estetica, durata e sostenibilità in ogni prodotto.

L'ottone costituisce l'anima e l'essenza primaria della rubinetteria, grazie alle sue proprietà meccaniche, riassunte nella facilità di lavorazione che lo rende adatto alla produzione di articoli dal design e dettagli più disparati. Robusto e durevole, questo materiale è in grado di sopportare ampie variazioni di temperatura, ad esempio tra acqua calda e fredda, senza mai deformarsi. Una lega che si rivela vincente anche dal lato estetico, grazie alla buona adesione con i rivestimenti superficiali che ne ampliano l'appeal e la progettualità estetica.



## BRASS

*Processing raw materials is an art passed down from artisans of the past: it requires skill and a deep knowledge of materials, even today, when innovation and technology form an integral part of the production cycle. A careful selection of high-quality raw materials reflects Newform's commitment to combining aesthetic excellence, durability, and sustainability in every product.*

*Brass forms the heart and primary essence of faucets, thanks to its mechanical properties, summarized in its ease of processing, which makes it suitable to produce items with a wide range of designs and details. Strong and durable, this material can withstand significant temperature variations, such as between hot and cold water, without ever deforming. An alloy that also proves successful from an aesthetic perspective, thanks to its good adhesion with surface coatings that enhance its appeal and aesthetic design. sustainability.*



## LAITON

*Travailler la matière première est un art hérité des artisans du passé : cela nécessite du savoir-faire et d'une connaissance approfondie des matériaux, même aujourd'hui, où l'innovation et la technologie font partie intégrante du cycle de production. Une sélection minutieuse de matières premières de haute qualité reflète l'engagement de Newform à conjuguer excellence esthétique, résistance et durabilité dans chaque produit.*

*Le laiton constitue l'âme et l'essence principale de la robinetterie, grâce à ses propriétés mécaniques, résumées par la facilité d'usinage qui le rend adapté à la production d'articles aux designs et détails variés. Robuste et durable, ce matériau est capable de supporter d'importantes variations de température, par exemple entre l'eau chaude et froide, sans jamais se déformer. Un alliage qui se révèle également gagnant sur le plan esthétique, grâce à la bonne adhésion avec les revêtements de surface qui en élargissent l'attrait et la conception esthétique.*



## MESSING

*Die Arbeit mit Rohstoffen ist eine Kunst, die von den Handwerkern der Vergangenheit geerbt wurde: Sie erfordert Meisterschaft und ein tiefes Wissen über Materialien, auch heute, wo Innovation und Technologie ein integraler Bestandteil des Produktionszyklus sind. Die sorgfältige Auswahl hochwertiger Rohstoffe spiegelt das Engagement von Newform wider, ästhetische Exzellenz, Langlebigkeit und Nachhaltigkeit in jedem Produkt zu vereinen.*

*Messing ist die Seele und das Hauptwesen der Armaturen, dank seiner mechanischen Eigenschaften, die sich in der einfachen Verarbeitung zusammenfassen, die es für die Herstellung von Artikeln mit den unterschiedlichsten Designs und Details geeignet macht. Dieses Material ist robust und langlebig und hält großen Temperaturschwankungen, z. B. zwischen heißem und kaltem Wasser, stand, ohne sich jemals zu verformen. Eine Legierung, die sich auch aus ästhetischer Sicht als Gewinner erweist, dank ihrer guten Haftung mit Oberflächenbeschichtungen, die ihre Attraktivität und ihr ästhetisches Design erweitern.*



## LATÓN

*Trabajar la materia prima es un arte heredado de los artesanos del pasado: requiere destreza y un profundo conocimiento de los materiales, incluso hoy en día, donde la innovación y la tecnología son parte integral del ciclo productivo. Una selección precisa de la materia prima de alta calidad refleja el compromiso de Newform en combinar excelencia estética, durabilidad y sostenibilidad en cada producto.*

*El latón constituye el alma y la esencia primaria de la grifería, gracias a sus propiedades mecánicas, resumidas en la facilidad de procesamiento que lo hace adecuado para la producción de artículos con diseños y detalles muy variados. Robusto y duradero, este material es capaz de soportar amplias variaciones de temperatura, como las que se producen entre agua caliente y fría, sin deformarse nunca. Una aleación que también resulta ganadora desde el punto de vista estético, gracias a su buena adherencia con los revestimientos superficiales que amplían su atractivo y la planificación estética.*

A close-up, high-angle photograph of a large pile of brass shavings and metal chips. The shavings are numerous, small, and have a characteristic conical or flake-like shape, with some showing spiral patterns from the cutting process. The color is a warm, golden-brown. The word "BRASS" is printed in white, bold, sans-serif capital letters across the center of the image.

**BRASS**

MODALITA' LETTURA LISTINO PREZZI E ORDINE ARTICOLI  
 READING MODE FOR PRICE LIST AND ORDER ITEMS  
 MODE DE LECTURE TARIFS ET COMMANDE ARTICLES  
 LESERMODUS PREISLISTE UND BESTELLUNG ARTIKEL  
 MODALIDAD DE LECTURA LISTA DE PRECIOS Y PEDIDO ARTÍCULOS

- CODICE MODELLO
- MODEL CODE
- CODE MODÈLE
- MODELLNUMMER
- CÓDIGO MODELO
- NOVITA' O MODELLO MODIFICATO
- NEW IN OR MODIFIED MODEL
- MODÈLE NOUVEAU OU MODIFIÉ
- NEUES ODER GEÄNDERTES MUSTER
- MODELO NUEVO O MODIFICADO

**71825** **new**

- Miscelatore monocomando per lavello con bocca L girevole e doccia estraibile.
- Single-lever sink mixer with L swivel spout and pull-out hand shower.
- Mitigeur monocommande évier avec bec L pivotant et douchette extractible.
- Einhebel-Spültischmischer mit schwenkbarem L-Auslauf und ausziehbarer Handbrause.
- Mezclador monomando para fregadero con caño con forma de L giratorio y ducha extraíble.

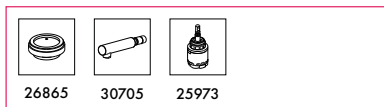

- 21.018 Chrome
- 01.093 Matt black
- 31.028 Brushed Nickel
- 59.064 PVD Br. Gun Metal
- 59.066 PVD Br. Stainless Steel
- 59.067 PVD Br. Copper Bronze
- 59.098 PVD Br. Pale Gold
- M0.077 Carbon Satin

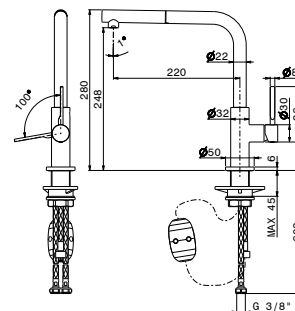

- REQUISITI MODELLO
- MODEL REQUIREMENTS
- CRITÈRES DU MODÈLE
- VORBILDICHE ANFORDERUNGEN
- REQUISITOS MODELO

- CODICE FINITURA
- FINISHING CODE
- CODE FINITION
- OBERFLÄCHEN-CODE
- CÓDIGO ACABADO

- CODICI RICAMBI E CARATTERISTICHE MODELLO
- SPARE PARTS CODES AND MODEL FEATURES
- CODES PIÈCES DÉTACHÉES ET CARACTÉRISTIQUES DU MODÈLE
- ERSATZTEILCODES UND MODELLMERKMALE
- CÓDIGOS REPUESTOS Y CARACTERÍSTICAS DEL MODELO

- PER ORDINARE L'ARTICOLO IN FINITURA:
- TO ORDER THE ARTICLE IN FINISH:
- POUR COMMANDER L'ARTICLE EN FINITION:
- ZUR BESTELLUNG DES ENDPRODUKTES
- PARA PEDIR EL ARTÍCULO EN ACABADO:

- In fase di ordine è necessario comporre il codice completo, composto dal codice modello + codice finitura.
- During the order process you must compose the complete code, composed of the model code + finishing code.
- Lors de la commande, il est nécessaire de composer le code complet, composé du code modèle + code finition.
- In der Bestellphase muss der vollständige Code gewählt werden, bestehend aus dem Modellcode + Endbearbeitungscode.
- En la fase de pedido es necesario marcar el código completo, compuesto por el código modelo + código acabado.

<b>71825</b>	+	<b>21.018</b>	=	<b>71825.21.018</b>
↑		↑		↑
<ul style="list-style-type: none"> <li>• CODICE MODELLO</li> <li>• MODEL CODE</li> <li>• CODE MODÈLE</li> <li>• MODELLCODE</li> <li>• CÓDIGO MODELO</li> </ul>	+	<ul style="list-style-type: none"> <li>• CODICE FINITURA</li> <li>• FINISHING CODE</li> <li>• CODE FINITION</li> <li>• OBERFLÄCHEN-CODE</li> <li>• CÓDIGO ACABADO</li> </ul>	=	<ul style="list-style-type: none"> <li>• CODICE ORDINE ARTICOLO</li> <li>• ORDER CODE ITEM</li> <li>• CODE DE COMMANDE ARTICLE</li> <li>• BESTELLCODE ARTIKEL</li> <li>• CÓDIGO DE PEDIDO ARTÍCULO</li> </ul>



- Al momento dell'ordine del ricambio si prega di indicare il prodotto su cui dovrà essere installato al fine di determinare il modello corretto da fornire, comprensivo di eventuale tampografia.
- When ordering the spare part, please specify the product it will be installed on, in order to determine the correct model to provide, including any required pad printing.
- Lors de la commande de la pièce détachée, veuillez indiquer le produit sur lequel sera installée afin de déterminer le modèle correct à fournir, y compris toute tampographie éventuelle.
- Bitte geben Sie bei der Bestellung des Ersatzteils das Produkt an, auf dem es installiert werden soll, um das richtige Modell einschließlich etwaiger Tampondrucke zu bestimmen.
- Al realizar el pedido del repuesto, indique el producto en el que se instalará para determinar el modelo correcto a suministrar, incluyendo cualquier tampografía necesaria.

LEGENDA ICONE RICAMBI  
 KEY TO SPARE PARTS ICONS  
 LÉGENDE DE ICÔNES PIÈCES DÉTACHÉES  
 IKONEN LEGENDE ERSATZTEILE  
 LEYENDA DE LOS ICONOS DE REPUESTOS

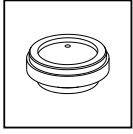

Aeratore.  
 Aerator.  
 Aérateur.  
 Wasserhahnbelüfter.  
 Aireador.

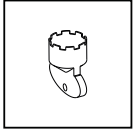

Chiave aeratore.  
 Aerator key.  
 Clé aérateur.  
 Schlüssel Wasserhahnbelüfter.  
 Clave de aireador.



Kit aeratore completo di chiave.  
 Aerator kit complete with key.  
 Kit aérateur complet avec clé.  
 Wasserhahnbelüfter mit Schlüssel.  
 Kit aireador completo de llave.

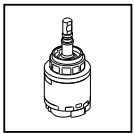

Cartuccia.  
 Cartridge.  
 Cartouche.  
 Kartusche.  
 Cartucho.

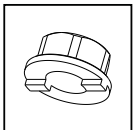

Chiave fix ghiera.  
 Fixing plug key.  
 Clé pour écrou de fixation.  
 Schlüssel für Ringmutterbefestigung.  
 Llave para anilla de fijación.

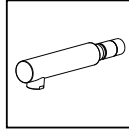

Doccetta "pull-out".  
 "Pull-out" hand shower.  
 Douchette extractible "pull-out".  
 "Pull-out" Handbrause.  
 Ducha extraíble "pull-out".

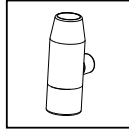

Doccetta "pull-down".  
 "Pull-down" hand shower.  
 Douchette extractible "pull-down".  
 "Pull-down" Handbrause.  
 Ducha extraíble "pull-down".

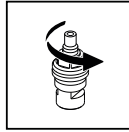

Vitone a dischi ceramici 90° apertura antioraria.  
 Ceramic disks cartridge 90° counterclockwise opening.  
 Têtes à disques céramiques 90° ouverture sens antihoraire.  
 Seitenventil, Keramikoberteil 90° entgegen Uhrzeigersinn Öffnung.  
 Mando discos cerámicos 90° apertura en sentido antihorario.

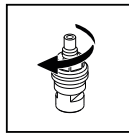

Vitone a dischi ceramici 90° apertura oraria.  
 Ceramic disks cartridge 90° clockwise opening.  
 Têtes à disques céramiques 90° ouverture sens horaire.  
 Seitenventil, Keramikoberteil 90° Uhrzeigersinn Öffnung.  
 Mando discos cerámicos 90° apertura en sentido horario.



# **KITCHEN EXPERIENCE**

**BRASS**



73300.59.064

ALKIMIA

# ALKIMIA encoder

acqua depurata  
purified water  
eau épurée



Trinkwasser  
agua purificada



acqua depurata fredda gassata  
cold sparkling purified water  
eau épurée froide gazeuse  
sprudel und gekühlt Trinkwasser  
agua purificada fría con gas

acqua depurata fredda  
cold purified water  
eau épurée froide  
gekühlt Trinkwasser  
agua purificada fría



## ACQUA A COMANDO

Attraverso il **comando elettronico girevole**, integrato al miscelatore, è possibile selezionare la tipologia di acqua depurata che si desidera: **fredda, fredda gassata** o a **temperatura ambiente**. Una multifunzionalità quasi inaspettata per un singolo miscelatore, che diventa un ricercato comfort dove la tecnologia fa la sua parte.



## WATER ON COMMAND

Using the **electronic rotary control**, integrated into the mixer tap, you can select the type of purified water you want: **cold, sparkling cold or room temperature**. An almost unexpected multifunctionality for a single mixer tap, which becomes a refined comfort where technology plays its part.

## EAU, À LA DEMANDE

Grâce à la **commande électronique rotative**, intégrée au mitigeur, il est possible de sélectionner le type d'eau épurée souhaité: **froide, froide gazeuse ou à température ambiante**. Une option multifonction presque inattendue pour un seul mitigeur, qui devient un confort recherché où la technologie joue son rôle.



**Alkimia** irrompe nell'ambiente cucina presentandosi nel nuovo codice colore **Soft Navy**, una tonalità opaca di blu notte che si unisce alla gamma di finiture Soft Color.

*Alkimia bursts into the kitchen environment in the new **Soft Navy** colour code, an opaque shade of night blue that joins the new range of Soft Color finishes.*

**Alkimia** fait irruption dans la cuisine en se présentant dans le nouveau code couleur **Soft Navy**, une teinte opaque de bleu nuit qui se joint à la nouvelle gamme de finitions Soft Color.

*Alkimia bricht in einem dunklen Kleid herein in die Küchenwelt und präsentiert sich in dem neuen Farbcode **Soft Navy**, ein matter Farbton in Mitternachtsblau, der sich in die Palette der Soft Color Oberflächen einreih.*

**Alkimia** irrumpe en la cocina presentándose en el nuevo código de color **Soft Navy**, una tonalidad azul noche mate que se suma a la gama de acabados Soft Color.

## WASSER AUF KOMMANDO

Durch die **elektronische Schwenksteuerung**, die in den Mischer integriert ist, ist es möglich, die Art des gereinigten Wassers auszuwählen, die man sich wünscht: **kalt, sprudelnd oder mit Raumtemperatur**. Eine fast unerwartete Multifunktionalität für eine einzelne Armatur, die zu einem begehrten Komfort wird, wobei die Technologie ihren Teil dazu beiträgt.

## AGUA A TU MANDO

A través del **mando electrónico giratorio**, integrado en el grifo, es posible seleccionar el tipo de agua purificada que se desea: **purificada fría, purificada fría sin gas o simplemente purificada**. Una multifuncionalidad casi inesperada para un único grifo, que se convierte en un confort sofisticado donde la tecnología aporta lo suyo.



# ALKIMIA

## outlets

La garanzia di un prodotto sicuro nelle mani dei consumatori è rafforzata non solo dalla presenza di due camere isolate per l'acqua sanitaria e depurata, ma dall'aggiunta in quest'ultima di un'uscita in acciaio inox AISI 316 - materiale ad alte prestazioni - connesso a tubo in polietilene certificato M.O.C.A.

Un dettaglio che accentua l'ampio e importante lavoro di ricerca di Newform nel progetto Alkimia.

*The guarantee of a safe product in the hands of consumers is reinforced not only by the presence of two insulated chambers for potable and purified water, but by the addition in the latter of an AISI 316 stainless-steel outlet - a high - performance material - connected to a M.O.C.A. certified polyethylene pipe. This detail accentuates the extensive and important research work Newform has conducted in the ALKIMIA project.*

La garantie d'un produit sûr entre les mains des consommateurs est renforcée non seulement par la présence de deux chambres isolées pour l'eau sanitaire et épurée, mais aussi par l'ajout dans cette dernière d'une sortie en acier inox AISI 316 (matériau haute performance) connecté à un tuyau en polyéthylène certifié M.O.C.A. Un détail qui souligne le vaste et important travail de recherche de Newform dans le projet Alkimia.

*Die Garantie eines sicheren Produkts in den Händen der Verbraucher, wird nicht nur durch das Vorhandensein von zwei isolierten Kammern für Brauchwasser und Trinkwasser bekräftigt, sondern auch durch die Hinzufügung in Letzterem von einem Belüfter aus Edelstahl AISI 316 - einem Material von hoher Leistungsfähigkeit -, der an ein M.O.C.A.-zertifiziertes Polyethylenrohr angeschlossen ist. Ein Detail, das die umfangreiche und wichtige Forschungsarbeit von Newform im Alkimia-Projekt unterstreicht.*

La garantía de un producto seguro en manos de los consumidores se refuerza no solo con la presencia de dos cámaras aisladas para el agua sanitaria y el agua purificada, sino también con la adición, en esta última, de una salida de acero inoxidable AISI 316 —material de alto rendimiento— conectada a una tubería de polietileno certificada M.O.C.A. Un detalle que destaca el amplio e importante trabajo de investigación de Newform en el proyecto Alkimia.

uscita acqua depurata

*purified water outlet*

*sortie d'eau épurée*

*Wasserauslauf Trinkwasser*

*salida de agua purificada*



uscita acqua uso domestico

*water outlet for domestic use*

*sortie d'eau domestique*

*Wasserauslauf Hausgebrauch*

*salida de agua para uso doméstico*



# ALKIMIA



**50.167** SOFT MAPLE



**50.169** SOFT NAVY



**M0.077** CARBON SATIN



**59.098** PVD BRUSHED PALE GOLD



**50.165** SOFT EUCALYPT



**50.166** SOFT CORTEX



**59.064** PVD BRUSHED GUN METAL



**59.066** PVD BRUSHED STAINLESS STEEL



**59.067** PVD BRUSHED COPPER BRONZE



**21.018** CROMO / CHROME



**01.014** BIANCO OPACO / MATT WHITE



**01.093** NERO OPACO / MATT BLACK

FULL STYLE



## 73300



ACME PIPE 1/4"

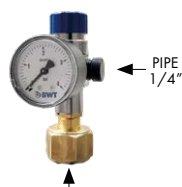

PIPE 1/4"



W21.7

- Sistema di filtraggio e refrigerazione acqua **completo** che comprende:
  - Miscelatore per lavello con comando elettronico;
  - Frigogasatore;
  - Cartuccia filtrante AQA drink AC 100;
  - Testata AQA drink MMW;
  - Kit riduttore di pressione CO2 per bombola attacco W21.7 e attacco tubo 1/4", con manometro 4 bar max.
  - Bombola CO2 ricaricabile da 2 Kg. con attacco W21.7.
  - Kit riduttore di pressione CO2 per bombola attacco Acme e attacco tubo da 1/4", senza manometro.

**Prodotto ordinabile esclusivamente per trasporto su ruote.**

- **Complete water filtration and cooling system including:**
  - Sink mixer tap with electronic control;
  - Carbonated water cooler;
  - AQA drink AC 100 filter cartridge;
  - AQA drink MMW nozzle;
  - CO2 pressure reducer kit for cylinder with W21.7 joint and 1/4" connection, with max. 4 bar pressure gauge;
  - CO2 cylinder 2 kg. with W21.7 joint
  - CO2 pressure reducer kit for cylinder with Acme joint and 1/4" connection, without pressure gauge.

**This product can be ordered exclusively for transport on wheels.**

- Système **complet** de filtration et de réfrigération de l'eau comprenant :
  - Mitigeur pour évier avec commande électronique ;
  - Système de réfrigération et gazéification de l'eau ;
  - Cartouche filtrante AQA drink AC 100 ;
  - Tête AQA drink MMW ;
  - Kit réducteur de pression CO2 pour bouteille avec raccord W21.7 et connexion 1/4", avec manomètre max. 4 bar ;
  - Bouteille de CO2 rechargeable de 2 kg avec raccord W21.7 ;
  - Kit réducteur de pression CO2 pour bouteille avec raccord Acme et connexion 1/4", sans manomètre.

**Produit pouvant être commandé exclusivement pour le transport sur roues.**

- **Komplettes Wasserfiltrations- und Kühlsystem, einschließlich:**
  - Spültischmischer mit elektronischer Steuerung;
  - gekühlter Wassersprudler;
  - Filterkartusche AQA Drink AC 100;
  - Zylinderkopf AQA-Drink MMW;
  - CO2-Druckminderer-Set für Flasche mit Anschluss W21.7 und 1/4"-Schlauchanschluss, mit Manometer bis max. 4 bar;
  - Wiederbefüllbare 2 Kg-CO2-Flasche und W21.7-Anschluss;
  - CO2-Druckminderer-Set für Flasche mit Acme-Anschluss und 1/4"-Schlauchanschluss, ohne Manometer.

**Dieses Produkt kann nur für den Transport auf Rädern bestellt werden.**

- Sistema **completo** de filtración y refrigeración del agua que incluye:
  - Mezclador para fregadero con control electrónico;
  - Sistema enfriador y gasificador de agua;
  - Cartucho filtrante AQA drink AC 100;
  - Cabezal AQA drink MMW;
  - Kit reductor de presión de CO2 para bombona con conexión W21.7 y toma de 1/4", con manómetro de presión máx. 4 bar;
  - Bombona recargable de CO2 de 2 kg con conexión W21.7;
  - Kit reductor de presión de CO2 para bombona con conexión Acme y toma de 1/4", sin manómetro.

**Producto disponible únicamente para transporte por carretera.**

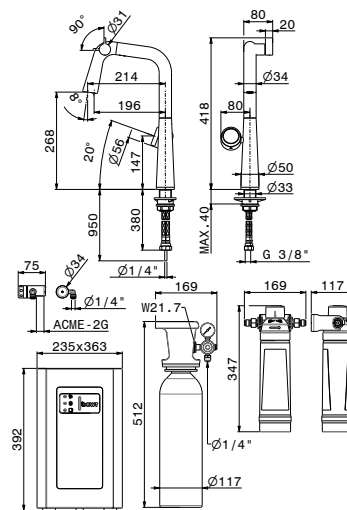

26825 13327 32409

● 21.018	Chrome	4.345,00	● 59.098	PVD Br. Pale Gold	4.811,00
● 01.014	Matt white	4.440,00	● S0.165	Soft Eucalypt	4.503,00
● 01.093	Matt black	4.440,00	● S0.166	Soft Cortex	4.503,00
● 59.064	PVD Br. Gun Metal	4.811,00	● S0.167	Soft Maple	4.503,00
● 59.066	PVD Br. Stainless Steel	4.811,00	● S0.169	Soft Navy	4.503,00
● 59.067	PVD Br. Copper Bronze	4.811,00	● M0.077	Carbon Satin	4.583,00





### 73305



- Sistema di filtraggio e refrigerazione acqua **completo** che comprende:
  - Miscelatore per lavello con comando elettronico;
  - Frigogasatore;
  - Cartuccia filtrante AQA drink AC 100;
  - Testata AQA drink MMW;
  - Kit riduttore di pressione CO<sub>2</sub> per bombola attacco Acme e attacco tubo da 1/4", senza manometro.
  - 4 bombole CO<sub>2</sub> ricaricabili da 425 gr. con attacco Acme;
  - Kit riduttore di pressione CO<sub>2</sub> per bombola attacco W21.7 e attacco tubo 1/4", con manometro 4 bar max.

**Prodotto ordinabile esclusivamente per trasporto su ruote.**

- **Complete water filtration and cooling system including:**
  - Sink mixer tap with electronic control;
  - Carbonated water cooler;
  - AQA drink AC 100 filter cartridge;
  - AQA Drink MMW nozzle;
  - CO<sub>2</sub> pressure reducer kit for cylinder with Acme joint and 1/4" connection, without pressure gauge.
  - 4 rechargeable CO<sub>2</sub> cylinders 425 gr. with Acme joint;
  - CO<sub>2</sub> pressure reducer kit for cylinder with W21.7 joint and 1/4" connection, with max. 4 bar pressure gauge;

**This product can be ordered exclusively for transport on wheels.**

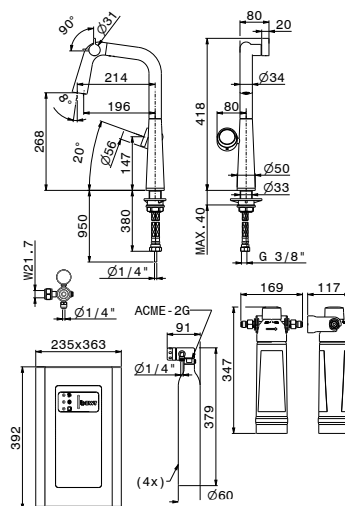

- Système **complet** de filtration et de réfrigération de l'eau comprenant :
  - Mitigeur pour évier avec commande électronique ;
  - Système de réfrigération et gazéification de l'eau ;
  - Cartouche filtrante AQA drink AC 100 ;
  - Tête AQA drink MMW ;
  - Kit réducteur de pression CO<sub>2</sub> pour bouteille avec raccord Acme et connexion 1/4", sans manomètre.
  - 4 bouteilles de CO<sub>2</sub> rechargeable de 425 gr avec raccord Acme ;
  - Kit réducteur de pression CO<sub>2</sub> pour bouteille avec raccord W21.7 et connexion 1/4", avec manomètre max. 4 bar ;

**Produit pouvant être commandé exclusivement pour le transport sur roues .**

- **Komplettes Wasserfiltrations- und Kühlsystem, einschließlich:**
  - Spültischmischer mit elektronischer Steuerung;
  - gekühlter Wassersprudler;
  - Filterkartusche AQA Drink AC 100;
  - Zylinderkopf AQA-Drink MMW;
  - CO<sub>2</sub>-Druckminderer-Set für Flasche mit Acme-Anschluss und 1/4"-Schlauchanschluss, ohne Manometer;
  - 4 wiederauffüllbare CO<sub>2</sub>-Flaschen von 425 g mit Acme-Anschluss;
  - CO<sub>2</sub>-Druckminderer-Set für Flasche mit W21.7-Anschluss und 1/4"-Schlauchanschluss, mit Manometer bis max. 4 bar;

**Dieses Produkt kann nur für den Transport auf Rädern bestellt werden.**

- Sistema **completo** de filtración y refrigeración del agua que incluye:
  - Mezclador para fregadero con control electrónico;
  - Sistema enfriador y gasificador de agua;
  - Cartucho filtrante AQA drink AC 100;
  - Cabezal AQA drink MMW;
  - Kit reductor de presión de CO<sub>2</sub> para bombona con conexión Acme y toma de 1/4", sin manómetro;
  - 4 bombonas recargables de CO<sub>2</sub> de 425 gr con conexión Acme;
  - Kit reductor de presión de CO<sub>2</sub> para bombona con conexión W21.7 y toma de 1/4", con manómetro de presión máx. 4 bar;

**Producto disponible únicamente para transporte por carretera.**



● 21.018	Chrome	<b>4.238,00</b>	● 59.098	PVD Br. Pale Gold	<b>4.722,00</b>
● 01.014	Matt white	<b>4.374,00</b>	● S0.165	Soft Eucalypt	<b>4.441,00</b>
● 01.093	Matt black	<b>4.374,00</b>	● S0.166	Soft Cortex	<b>4.441,00</b>
● 59.064	PVD Br. Gun Metal	<b>4.722,00</b>	● S0.167	Soft Maple	<b>4.441,00</b>
● 59.066	PVD Br. Stainless Steel	<b>4.722,00</b>	● S0.169	Soft Navy	<b>4.441,00</b>
● 59.067	PVD Br. Copper Bronze	<b>4.722,00</b>	● M0.077	Carbon Satin	<b>4.473,00</b>





### 73304 new

- Miscelatore per lavello con bocca girevole.
- Sink mixer tap with swivel spout.
- Mitigeur pour évier avec bec pivotant .
- Spültischmischer mit schwenkbarem Auslauf.
- Mezclador para fregadero con caño giratorio.



● 21.018	Chrome	<b>937,00</b>	● 59.098	PVD Br. Pale Gold	<b>1.357,00</b>
● 01.014	Matt white	<b>989,00</b>	● S0.165	Soft Eucalypt	<b>1.030,00</b>
● 01.093	Matt black	<b>989,00</b>	● S0.166	Soft Cortex	<b>1.030,00</b>
● 59.064	PVD Br. Gun Metal	<b>1.357,00</b>	● S0.167	Soft Maple	<b>1.030,00</b>
● 59.066	PVD Br. Stainless Steel	<b>1.357,00</b>	● S0.169	Soft Navy	<b>1.030,00</b>
● 59.067	PVD Br. Copper Bronze	<b>1.357,00</b>	● M0.077	Carbon Satin	<b>1.150,00</b>

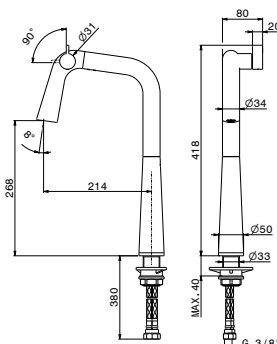

### 73306 new

- Miscelatore per lavello con bocca girevole e comando remoto per acqua depurata che comprende:
  - Cartuccia filtrante AQA drink AC 100;
  - Testata AQA drink MMW.

- Sink mixer tap with swivel spout and remote control for purified water, including:
  - AQA drink AC 100 filter cartridge;
  - AQA Drink MMW nozzle.

- Mitigeur pour évier avec bec pivotant et commande à distance pour eau purifiée comprenant:
  - Cartouche filtrante AQA drink AC 100 ;
  - Tête AQA drink MMW .

- Spültischarmatur mit schwenkbarem Auslauf und Fernbedienung für gereinigtes Wasser.
  - AQA drink AC 100 filter cartridge;
  - AQA Drink MMW nozzle.

- Mezclador para fregadero con caño giratorio y control remoto para agua purificada que incluye:
  - Cartucho filtrante AQA drink AC 100;
  - Cabezal AQA drink MMW.



● 21.018	Chrome	<b>1.467,00</b>	● 59.098	PVD Br. Pale Gold	<b>1.923,00</b>
● 01.014	Matt white	<b>1.498,00</b>	● S0.165	Soft Eucalypt	<b>1.542,00</b>
● 01.093	Matt black	<b>1.498,00</b>	● S0.166	Soft Cortex	<b>1.542,00</b>
● 59.064	PVD Br. Gun Metal	<b>1.923,00</b>	● S0.167	Soft Maple	<b>1.542,00</b>
● 59.066	PVD Br. Stainless Steel	<b>1.923,00</b>	● S0.169	Soft Navy	<b>1.542,00</b>
● 59.067	PVD Br. Copper Bronze	<b>1.923,00</b>	● M0.077	Carbon Satin	<b>1.617,00</b>

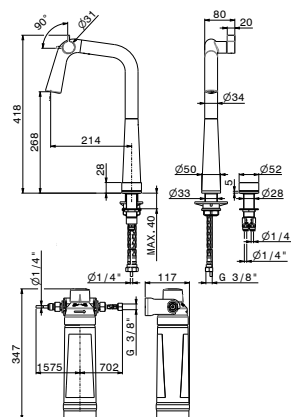

RICAMBI / SPARE PARTS / PIÈCES DÉTACHÉES / ERSATZTEILE / REPUESTOS

Al momento dell'ordine del ricambio si prega di indicare il prodotto su cui dovrà essere installato al fine di determinare il modello corretto da fornire, comprensivo di eventuale tampografia.  
 When ordering the spare part, please specify the product it will be installed on, in order to determine the correct model to provide, including any required pad printing.  
 Lors de la commande de la pièce détachée, veuillez indiquer le produit sur lequel sera installée afin de déterminer le modèle correct à fournir, y compris toute tampographie éventuelle.  
 Bitte geben Sie bei der Bestellung des Ersatzteils das Produkt an, auf dem es installiert werden soll, um das richtige Modell einschließlich etwaiger Tampondrucke zu bestimmen.  
 Al realizar el pedido del repuesto, indique el producto en el que se instalará para determinar el modelo correcto a suministrar, incluyendo cualquier tampografía necesaria.

73302



- Miscelatore per lavello con bocca girevole, flessibili di alimentazione F3/8" e comando elettronico per acqua depurata.
- Sink mixer tap with swivel spout, F3/8" connection hoses and electronic control for purified water.
- Mitigeur pour évier avec bouche pivotante, flexibles d'alimentation F3/8" et commande électronique pour l'eau épurée.
- Spültischmischer mit schwenkbarem Auslauf, F3/8"-Versorgungsschläuchen und elektronischer Steuerung für gereinigtes Trinkwasser.
- Mezclador para fregadero con caño giratorio, flexibles de alimentación F3/8" y control electrónico para agua purificada.



26825 13327 32409

● 21.018	Chrome	1.805,00
● 01.014	Matt white	1.892,00
● 01.093	Matt black	1.892,00
● 59.064	PVD Br. Gun Metal	2.303,00
● 59.066	PVD Br. Stainless Steel	2.303,00
● 59.067	PVD Br. Copper Bronze	2.303,00
● 59.098	PVD Br. Pale Gold	2.303,00
● S0.165	Soft Eucalypt	1.923,00
● S0.166	Soft Cortex	1.923,00
● S0.167	Soft Maple	1.923,00
● S0.169	Soft Navy	1.923,00
● M0.077	Carbon Satin	1.991,00

32403



- Testata AQA drink MMW.
- AQA drink MMW nozzle.
- Tête AQA drink MMW.
- Zylinderkopf AQA-Drink MMW.
- Cabezal AQA drink MMW.

00.000 Neutral 117,00

32402



- Cartuccia filtrante AQA drink AC 100.
- AQA drink AC 100 filter cartridge.
- Cartouche filtrante AQA drink AC 100.
- Filterkartusche AQA Drink AC 100.
- Cartucho filtrante AQA drink AC 100.

00.000 Neutral 137,00

73303



- Frigogasatore BWT AQA DRINK 20U senza bombola CO2 che comprende:
  - Frigogasatore;
  - Testata AQA drink MMW;
  - Cartuccia filtrante AQA drink AC 100;
  - Kit riduttore di pressione CO2." "BWT
- AQA DRINK 20U carbonated water cooler without CO2 cylinder, including:
  - Carbonated water cooler;
  - AQA drink MMW nozzle;
  - AQA drink AC 100 filter cartridge;
  - CO2 pressure regulator kit.
- Fontaine à eau BWT AQA DRINK 20U sans bouteille de CO2 comprenant :
  - Fontaine à eau ;
  - Tête AQA drink MMW ;
  - Cartouche filtrante AQA drink AC 100 ;
  - Kit réducteur de pression CO2 .
- Gekühlter Wassersprudler BWT AQA DRINK 20U ohne CO2-Flasche, bestehend aus:
  - gekühlter Wassersprudler;
  - Zylinderkopf AQA Drink MMW;
  - Filterkartusche AQA Drink AC 100;
  - CO2-Druckminderungs-Set.
- Dispensador de agua con gas BWT AQA DRINK 20U sin botella de CO2 que incluye:
  - Dispensador de agua con gas;
  - Cabezal AQA drink MMW;
  - Cartucho filtrante AQA drink AC 100;
  - Kit reductor de presión CO2.

32405

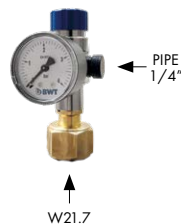

- Kit riduttore di pressione CO2 per bombola attacco W21.7 e attacco tubo 1/4", con manometro 4 bar max.
- CO2 pressure reducer kit for cylinder with W21.7 joint and 1/4" connection, with max. 4 bar pressure gauge.
- Kit réducteur de pression CO2 pour bouteille avec raccord W21.7 et connexion 1/4", avec manomètre max. 4 bar .
- CO2-Druckminderer-Set für Flasche mit W21.7-Anschluss und 1/4"-Schlauchanschluss, mit Manometer bis max. 4 bar.
- Kit reductor de presión de CO2 para bombona con conexión W21.7 y toma de 1/4", con manómetro de presión máx. 4 bar.

00.000 Neutral 2.361,00

00.000 Neutral 180,00

RICAMBI / SPARE PARTS / PIÈCES DÉTACHÉES / ERSATZTEILE / REPUESTOS

Al momento dell'ordine del ricambio si prega di indicare il prodotto su cui dovrà essere installato al fine di determinare il modello corretto da fornire, comprensivo di eventuale tampografia.  
 When ordering the spare part, please specify the product it will be installed on, in order to determine the correct model to provide, including any required pad printing.  
 Lors de la commande de la pièce détachée, veuillez indiquer le produit sur lequel sera installée afin de déterminer le modèle correct à fournir, y compris toute tampographie éventuelle.  
 Bitte geben Sie bei der Bestellung des Ersatzteils das Produkt an, auf dem es installiert werden soll, um das richtige Modell einschließlich etwaiger Tampondrucke zu bestimmen.  
 Al realizar el pedido del repuesto, indique el producto en el que se instalará para determinar el modelo correcto a suministrar, incluyendo cualquier tampografía necesaria.

**32432**

- Kit riduttore di pressione CO<sub>2</sub> per bombola attacco Acme e attacco tubo da 1/4", senza manometro.
- CO<sub>2</sub> pressure reducer kit for cylinder with Acme joint and 1/4" connection, without pressure gauge.
- Kit réducteur de pression CO<sub>2</sub> pour bouteille avec raccord Acme et connexion 1/4", sans manomètre
- CO<sub>2</sub>-Druckminderer-Set für Flasche mit Acme-Anschluss und 1/4"-Schlauchanschluss, ohne Manometer.
- Kit reductor de presión de CO<sub>2</sub> para bombona con conexión Acme y toma de 1/4", sin manómetro.



○ 00.000 Neutral **147,00**

**32411**

- Pastiglia EasyCare sanificazione.
- EasyCare sanitizing tablet.
- Pastille EasyCare de désinfection .
- EasyCare Desinfektionstablette.
- Tableta EasyCare desinfectante.



○ 00.000 Neutral **69,00**

**32471**

- Sistema di sanificazione BWT EasyCare.
- BWT EasyCare Sanitization System.
- Système de désinfection BWT EasyCare.
- Sistema de desinfección BWT EasyCare.
- BWT EasyCare-Desinfektionssystem.



○ 00.000 Neutral **112,00**

RICAMBI / SPARE PARTS / PIÈCES DÉTACHÉES / ERSATZTEILE / REPUESTOS

Al momento dell'ordine del ricambio si prega di indicare il prodotto su cui dovrà essere installato al fine di determinare il modello corretto da fornire, comprensivo di eventuale tampografia.  
 When ordering the spare part, please specify the product it will be installed on, in order to determine the correct model to provide, including any required pad printing.  
 Lors de la commande de la pièce détachée, veuillez indiquer le produit sur lequel sera installée afin de déterminer le modèle correct à fournir, y compris toute tampographie éventuelle.  
 Bitte geben Sie bei der Bestellung des Ersatzteils das Produkt an, auf dem es installiert werden soll, um das richtige Modell einschließlich etwaiger Tampondrucke zu bestimmen.  
 Al realizar el pedido del repuesto, indique el producto en el que se instalará para determinar el modelo correcto a suministrar, incluyendo cualquier tampografía necesaria.

**32470**

- Maniglia completa per collezione ALKIMIA.
- Complete handle for ALKIMIA collection.
- Manette complète pour collection ALKIMIA .
- Griff für die Küchenkollektion ALKIMIA.
- Manija completa para colección ALKIMIA.



● 21.018	Chrome	39,00
● 01.014	Matt white	48,00
● 01.093	Matt black	48,00
● 59.064	PVD Br. Gun Metal	77,00
● 59.066	PVD Br. Stainless Seel	77,00
● 59.067	PVD Br. Copper Bronze	77,00
● 59.098	PVD Br. Pale Gold	77,00
● S0.165	Soft Eucalypt	54,00
● S0.166	Soft Cortex	54,00
● S0.167	Soft Maple	54,00
● S0.169	Soft Navy	54,00
● M0.077	Carbon Satin	52,00

**32440**

- Maniglia per art.:
- Handle for art.:
- Manette pour art.:
- Griff für art.:
- Manija para art.:



**73306.**

● 21.018	Chrome	59,00
● 01.014	Matt white	63,00
● 01.093	Matt black	63,00
● 59.064	PVD Br. Gun Metal	86,00
● 59.066	PVD Br. Stainless Seel	86,00
● 59.067	PVD Br. Copper Bronze	86,00
● 59.098	PVD Br. Pale Gold	86,00
● S0.165	Soft Eucalypt	72,00
● S0.166	Soft Cortex	72,00
● S0.167	Soft Maple	72,00
● S0.169	Soft Navy	72,00
● M0.077	Carbon Satin	69,00

**32413**

- Ghiera di fissaggio per cartuccia.
- Fixing plug for cartridge.
- Bouchon de fixation .
- Befestigungsring für Einhebel-Mischer.
- Anilla de fijación para cartucho.



○ 00.000	Neutral	36,00
----------	---------	-------

**32412**

- Cappuccio coprighiera.
- Cover ring nut cap.
- Cache écrou couvre-joint .
- Ringverkleidung.
- Embellecedor de anilla.



● 21.018	Chrome	47,00
● 01.014	Matt white	52,00
● 01.093	Matt black	52,00
● 59.064	PVD Br. Gun Metal	67,00
● 59.066	PVD Br. Stainless Seel	67,00
● 59.067	PVD Br. Copper Bronze	67,00
● 59.098	PVD Br. Pale Gold	67,00
● S0.165	Soft Eucalypt	57,00
● S0.166	Soft Cortex	57,00
● S0.167	Soft Maple	57,00
● S0.169	Soft Navy	57,00
● M0.077	Carbon Satin	53,00

**10237**

- Vitone apertura antioraria per art.:
- Valve counterclockwise opening for art.:
- Tête ouverture sens antihoraire pour art.:
- Seitenventil, entgegen Uhrzeigersinn Öffnung für art.:
- Mando apertura en sentido antihorario para art.:



**73306.**

○ 00.000	Neutral	44,00
----------	---------	-------

**32409**

- Cartuccia a dischi ceramici.
- Cartridge with ceramic discs.
- Cartouche à disque céramique .
- Keramikscheibenkartusche.
- Cartucho de discos cerámicos.



○ 00.000	Neutral	49,00
----------	---------	-------



# KONBU



**50.167** SOFT MAPLE



**M0.077** CARBON SATIN



**59.098** PVD BRUSHED PALE GOLD



**50.165** SOFT EUCALYPT



**50.166** SOFT CORTEX



**59.064** PVD BRUSHED GUN METAL



new

**59.066** PVD BRUSHED STAINLESS STEEL



**59.067** PVD BRUSHED COPPER BRONZE



**21.018** CROMO / CHROME



**01.093** NERO OPACO / MATT BLACK



**31.028** NICKEL SPAZZOLATO  
BRUSHED NICKEL

FULL STYLE





### 72521

- Miscelatore monocomando per lavello con bocca tonda girevole.
- Single-lever sink mixer with round swivel spout.
- Mitigeur monocommande évier avec bec rond pivotant .
- Einhebel-Spültischmischer mit rundem Schwenkauslauf.
- Mezclador monomando para fregadero con caño redondo giratorio.



26883 25973

● 21.018	Chrome	330,00	● 59.098	PVD Br. Pale Gold	786,00
● 01.093	Matt black	412,00	● S0.165	Soft Eucalypt	445,00
● 31.028	Brushed Nickel	386,00	● S0.166	Soft Cortex	445,00
● 59.064	PVD Br. Gun Metal	786,00	● S0.167	Soft Maple	445,00
● 59.066	PVD Br. Stainless Seel	786,00	● M0.077	Carbon Satin	495,00
● 59.067	PVD Br. Copper Bronze	786,00			

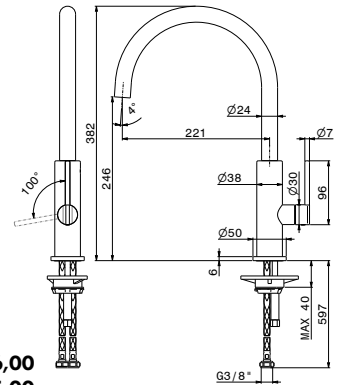

### 72525

- Miscelatore monocomando per lavello con bocca tonda girevole e doccetta estraibile.
- Single-lever sink mixer with round swivel spout and pull-out hand shower.
- Mitigeur monocommande évier avec bec rond pivotant et douchette extractible .
- Einhebel-Spültischmischer mit rundem Schwenkauslauf und ausziehbarer Handbrause.
- Mezclador monomando para fregadero con caño redondo giratorio y ducha extraíble.

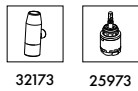

32173 25973

● 21.018	Chrome	472,00	● 59.098	PVD Br. Pale Gold	879,00
● 01.093	Matt black	544,00	● S0.165	Soft Eucalypt	598,00
● 31.028	Brushed Nickel	554,00	● S0.166	Soft Cortex	598,00
● 59.064	PVD Br. Gun Metal	879,00	● S0.167	Soft Maple	598,00
● 59.066	PVD Br. Stainless Seel	879,00	● M0.077	Carbon Satin	619,00
● 59.067	PVD Br. Copper Bronze	879,00			

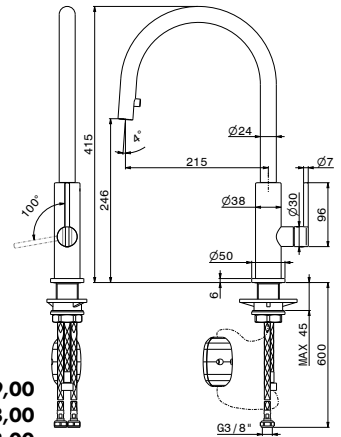

### 72520

- Miscelatore monocomando per lavello con bocca quadra girevole.
- Single-lever sink mixer with squared swivel spout.
- Mitigeur monocommande évier avec bec carré pivotant .
- Einhebel-Spültischmischer mit quadratischem Schwenkauslauf.
- Mezclador monomando para fregadero con caño cuadrado giratorio.



26883 25973

● 21.018	Chrome	349,00	● 59.098	PVD Br. Pale Gold	799,00
● 01.093	Matt black	420,00	● S0.165	Soft Eucalypt	462,00
● 31.028	Brushed Nickel	392,00	● S0.166	Soft Cortex	462,00
● 59.064	PVD Br. Gun Metal	799,00	● S0.167	Soft Maple	462,00
● 59.066	PVD Br. Stainless Seel	799,00	● M0.077	Carbon Satin	512,00
● 59.067	PVD Br. Copper Bronze	799,00			

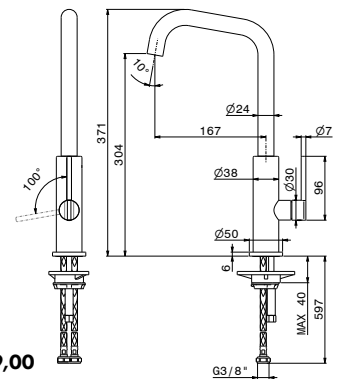

## 72522

- Miscelatore monocomando per lavello con bocca L girevole.
- *Single-lever sink mixer with L swivel spout.*
- Mitigeur monocommande évier avec bec L pivotant .
- *Einhebel-Spültischmischer mit drehbarem L-Auslauf.*
- Mezclador monomando para fregadero con caño con forma de L giratorio.



26884 25973

● 21.018	Chrome	365,00	● 59.098	PVD Br. Pale Gold	849,00
● 01.093	Matt black	426,00	● S0.165	Soft Eucalypt	468,00
● 31.028	Brushed Nickel	439,00	● S0.166	Soft Cortex	468,00
● 59.064	PVD Br. Gun Metal	849,00	● S0.167	Soft Maple	468,00
● 59.066	PVD Br. Stainless Seel	849,00	● M0.077	Carbon Satin	524,00
● 59.067	PVD Br. Copper Bronze	849,00			

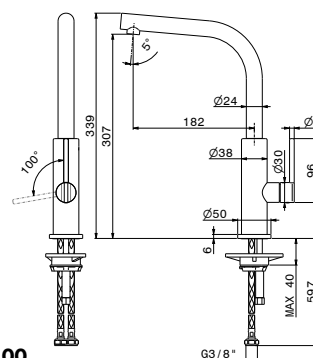

SAVE WATER ENERGY SAVING LOW LEAD

## 72535

- Miscelatore monocomando per lavello con bocca L girevole e doccia estraibile.
- *Single-lever sink mixer with L swivel spout and pull-out hand shower.*
- Mitigeur monocommande évier avec bec L pivotant et douchette extractible .
- *Einhebel-Spültischmischer mit schwenkbarem L-Auslauf und ausziehbarer Handbrause.*
- Mezclador monomando para fregadero con caño con forma de L giratorio y ducha extraíble.

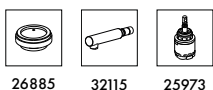

26885 32115 25973

● 21.018	Chrome	498,00	● 59.098	PVD Br. Pale Gold	976,00
● 01.093	Matt black	569,00	● S0.165	Soft Eucalypt	629,00
● 31.028	Brushed Nickel	578,00	● S0.166	Soft Cortex	629,00
● 59.064	PVD Br. Gun Metal	976,00	● S0.167	Soft Maple	629,00
● 59.066	PVD Br. Stainless Seel	976,00	● M0.077	Carbon Satin	675,00
● 59.067	PVD Br. Copper Bronze	976,00			

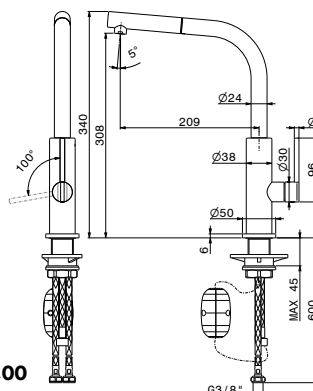

SAVE WATER ENERGY SAVING LOW LEAD

## 72545

- Miscelatore monocomando **semiprofessionale** per lavello con bocca girevole e orientabile.
- **Semiprofessiona** *single-lever sink mixer with round swivel spout.*
- Mitigeur monocommande évier **semi-professionnel** avec bec pivotant et orientable .
- **Semiprofessioneller** *Einhebel-Spültischmischer mit schwenk- und verstellbarem Auslauf.*
- Mezclador monomando **semiprofessional** para fregadero con caño giratorio y orientable.

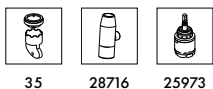

35 28716 25973

● 05.093	Chrome + Matt black	565,00	● 57.098	PVD Br. Pale Gold + Matt black	1.031,00
● 01.093	Matt black	615,00	● S2.165	Soft Eucalypt + M. black	678,00
● 33.093	Brushed Nickel+M. black	611,00	● S2.166	Soft Cortex + M. black	678,00
● 57.064	PVD Br. Gun Metal + Matt black	1.031,00	● S2.167	Soft Maple + M. black	678,00
● 57.066	PVD Br. Stainless Seel + Matt black	1.031,00	● M2.077	Carbon Satin + M. black	683,00
● 57.067	PVD Br. Copper Bronze + Matt black	1.031,00			

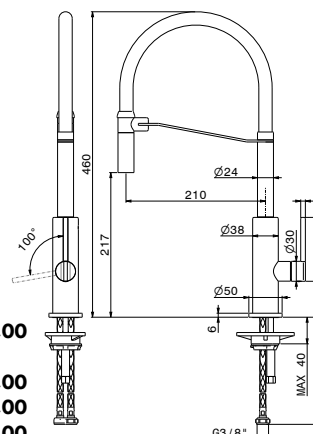

SAVE WATER ENERGY SAVING LOW LEAD

## 2418

- Dispenser per sapone liquido.
- Soap dispenser.
- Distributeur de savon .
- Flüssigseifenspender.
- Dispensador de jabón líquido.



● <b>21.018</b> Chrome	<b>159,00</b>	● <b>59.098</b> PVD Br. Pale Gold	<b>251,00</b>
● <b>01.093</b> Matt black	<b>169,00</b>	● <b>S0.165</b> Soft Eucalypt	<b>187,00</b>
● <b>31.028</b> Brushed Nickel	<b>204,00</b>	● <b>S0.166</b> Soft Cortex	<b>187,00</b>
● <b>59.064</b> PVD Br. Gun Metal	<b>251,00</b>	● <b>S0.167</b> Soft Maple	<b>187,00</b>
● <b>59.066</b> PVD Br. Stainless Steel	<b>251,00</b>	● <b>M0.077</b> Carbon Satin	<b>203,00</b>
● <b>59.067</b> PVD Br. Copper Bronze	<b>251,00</b>		

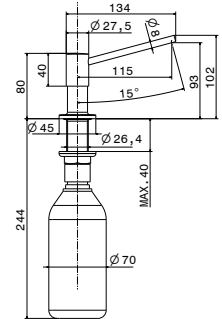

Al momento dell'ordine del ricambio si prega di indicare il prodotto su cui dovrà essere installato al fine di determinare il modello corretto da fornire, comprensivo di eventuale tampografia.  
 When ordering the spare part, please specify the product it will be installed on, in order to determine the correct model to provide, including any required pad printing.  
 Lors de la commande de la pièce détachée, veuillez indiquer le produit sur lequel sera installée afin de déterminer le modèle correct à fournir, y compris toute tampographie éventuelle.  
 Bitte geben Sie bei der Bestellung des Ersatzteils das Produkt an, auf dem es installiert werden soll, um das richtige Modell einschließlich etwaiger Tampondrucke zu bestimmen.  
 Al realizar el pedido del repuesto, indique el producto en el que se instalará para determinar el modelo correcto a suministrar, incluyendo cualquier tampografía necesaria.

### 32170



- Maniglia completa per collezione KONBU.
- Complete handle for KONBU collection.
- Manette complète pour collection KONBU.
- Griff für die Küchenkollektion KONBU.
- Manija completa para colección KONBU.

● 21.018	Chrome	51,00
● 01.093	Matt black	69,00
● 31.028	Brushed Nickel	63,00
● 59.064	PVD Br. Gun Metal	103,00
● 59.066	PVD Br. Stainless Steel	103,00
● 59.067	PVD Br. Copper Bronze	103,00
● 59.098	PVD Br. Pale Gold	103,00
● S0.165	Soft Eucalypt	78,00
● S0.166	Soft Cortex	78,00
● S0.167	Soft Maple	78,00
● M0.077	Carbon Satin	79,00

### 28716



- Doccetta per art.:
- Hand shower for art.:
- Douchette pour art.:
- Handbrause für Art.-Nr.:
- Ducha para art.:

72545.

● 21.018	Chrome	68,00
● 01.093	Matt black	74,00
● 31.028	Brushed Nickel	77,00
● 59.064	PVD Br. Gun Metal	88,00
● 59.066	PVD Br. Stainless Steel	88,00
● 59.067	PVD Br. Copper Bronze	88,00
● 59.098	PVD Br. Pale Gold	88,00
● S0.165	Soft Eucalypt	81,00
● S0.166	Soft Cortex	81,00
● S0.167	Soft Maple	81,00
● M0.077	Carbon Satin	81,00



### 32106



- Cappuccio coprighiera.
- Cover ring nut cap.
- Cache écrou couvre-joint.
- Ringverkleidung.
- Embellecedor de anilla.

● 21.018	Chrome	43,00
● 01.093	Matt black	46,00
● 31.028	Brushed Nickel	46,00
● 59.064	PVD Br. Gun Metal	59,00
● 59.066	PVD Br. Stainless Steel	59,00
● 59.067	PVD Br. Copper Bronze	59,00
● 59.098	PVD Br. Pale Gold	59,00
● S0.165	Soft Eucalypt	49,00
● S0.166	Soft Cortex	49,00
● S0.167	Soft Maple	49,00
● M0.077	Carbon Satin	48,00

### 32115



- Doccetta per art.:
- Hand shower for art.:
- Douchette pour art.:
- Handbrause für Art.-Nr.:
- Ducha para art.:

72535.

● 21.018	Chrome	65,00
● 01.093	Matt black	99,00
● 31.028	Brushed Nickel	105,00
● 59.064	PVD Br. Gun Metal	139,00
● 59.066	PVD Br. Stainless Steel	139,00
● 59.067	PVD Br. Copper Bronze	139,00
● 59.098	PVD Br. Pale Gold	139,00
● S0.165	Soft Eucalypt	111,00
● S0.166	Soft Cortex	111,00
● S0.167	Soft Maple	111,00
● M0.077	Carbon Satin	115,00



### 32107



- Ghiera di fissaggio per cartuccia.
- Fixing plug for cartridge.
- Bouchon de fixation.
- Befestigungsring für Einhebel-Mischer.
- Anilla de fijación para cartucho.

○ 00.000	Neutral	38,00
----------	---------	-------

### 32173



- Doccetta per art.:
- Hand shower for art.:
- Douchette pour art.:
- Handbrause für Art.-Nr.:
- Ducha para art.:

72525.

● 21.018	Chrome	57,00
● 01.093	Matt black	60,00
● 31.028	Brushed Nickel	63,00
● 59.064	PVD Br. Gun Metal	73,00
● 59.066	PVD Br. Stainless Steel	73,00
● 59.067	PVD Br. Copper Bronze	73,00
● 59.098	PVD Br. Pale Gold	73,00
● S0.165	Soft Eucalypt	65,00
● S0.166	Soft Cortex	65,00
● S0.167	Soft Maple	65,00
● M0.077	Carbon Satin	69,00



### 25973



- Cartuccia a dischi ceramici.
- Cartridge with ceramic discs.
- Cartouche à disque céramique.
- Keramikscheibenkartusche.
- Cartucho de discos cerámicos.

○ 00.000	Neutral	49,00
----------	---------	-------

# MAKI



**57.098** PVD BRUSHED PALE GOLD  
MATT BLACK



**M2.077** CARBON SATIN  
MATT BLACK



**57.064** PVD BRUSHED GUN METAL  
MATT BLACK



new

**57.066** PVD BRUSHED STAINLESS STEEL  
MATT BLACK



**57.067** PVD BRUSHED COPPER BRONZE  
MATT BLACK



**05.093** CHROME / MATT BLACK



**01.093** NERO OPACO / MATT BLACK



**33.093** BRUSHED NICKEL / MATT BLACK

FULL STYLE



## 71820

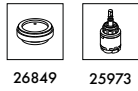

26849 25973

● <b>21.018</b> Chrome	<b>254,00</b>	● <b>59.066</b> PVD Br. Stainless Steel	<b>606,00</b>
● <b>01.093</b> Matt black	<b>316,00</b>	● <b>59.067</b> PVD Br. Copper Bronze	<b>606,00</b>
● <b>31.028</b> Brushed Nickel	<b>297,00</b>	● <b>59.098</b> PVD Br. Pale Gold	<b>606,00</b>
● <b>59.064</b> PVD Br. Gun Metal	<b>606,00</b>	● <b>M0.077</b> Carbon Satin	<b>388,00</b>

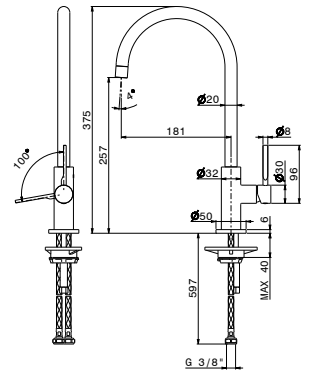

## 71821

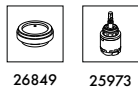

26849 25973

● <b>21.018</b> Chrome	<b>268,00</b>	● <b>59.066</b> PVD Br. Stainless Steel	<b>599,00</b>
● <b>01.093</b> Matt black	<b>329,00</b>	● <b>59.067</b> PVD Br. Copper Bronze	<b>599,00</b>
● <b>31.028</b> Brushed Nickel	<b>307,00</b>	● <b>59.098</b> PVD Br. Pale Gold	<b>599,00</b>
● <b>59.064</b> PVD Br. Gun Metal	<b>599,00</b>	● <b>M0.077</b> Carbon Satin	<b>395,00</b>

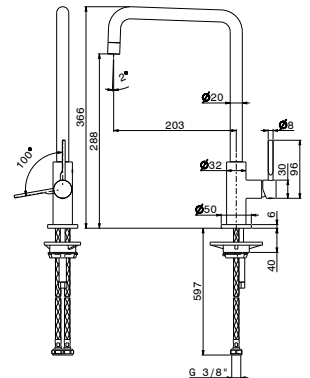

## 71822



26882 25973

● <b>21.018</b> Chrome	<b>282,00</b>	● <b>59.066</b> PVD Br. Stainless Steel	<b>649,00</b>
● <b>01.093</b> Matt black	<b>329,00</b>	● <b>59.067</b> PVD Br. Copper Bronze	<b>649,00</b>
● <b>31.028</b> Brushed Nickel	<b>337,00</b>	● <b>59.098</b> PVD Br. Pale Gold	<b>649,00</b>
● <b>59.064</b> PVD Br. Gun Metal	<b>649,00</b>	● <b>M0.077</b> Carbon Satin	<b>403,00</b>

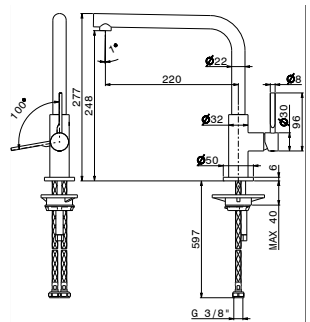

## 71823

- Miscelatore monocomando per lavello con bocca L girevole.
- *Single-lever sink mixer with L swivel spout.*
- Mitigeur monocommande évier avec bec L pivotant .
- *Einhebel-Spültischmischer mit drehbarem L-Auslauf.*
- Mezclador monomando para fregadero con caño con forma de L giratorio.

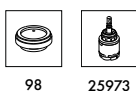

98 25973

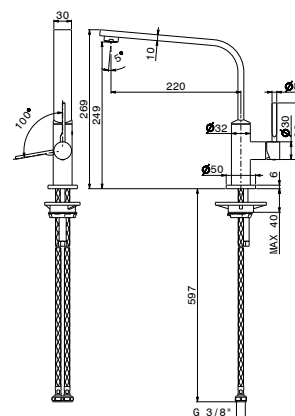

● 21.018	Chrome	313,00	● 59.066	PVD Br. Stainless Steel	680,00
● 01.093	Matt black	359,00	● 59.067	PVD Br. Copper Bronze	680,00
● 31.028	Brushed Nickel	372,00	● 59.098	PVD Br. Pale Gold	680,00
● 59.064	PVD Br. Gun Metal	680,00	● M0.077	Carbon Satin	429,00

## 71825

- Miscelatore monocomando per lavello con bocca L girevole e doccia estraibile.
- *Single-lever sink mixer with L swivel spout and pull-out hand shower.*
- Mitigeur monocommande évier avec bec L pivotant et douchette extractible .
- *Einhebel-Spültischmischer mit schwenkbarem L-Auslauf und ausziehbarer Handbrause.*
- Mezclador monomando para fregadero con caño con forma de L giratorio y ducha extraíble.

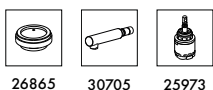

26865 30705 25973

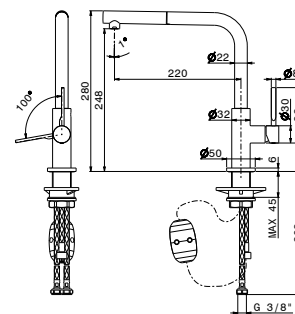

● 21.018	Chrome	382,00	● 59.066	PVD Br. Stainless Steel	783,00
● 01.093	Matt black	453,00	● 59.067	PVD Br. Copper Bronze	783,00
● 31.028	Brushed Nickel	439,00	● 59.098	PVD Br. Pale Gold	783,00
● 59.064	PVD Br. Gun Metal	783,00	● M0.077	Carbon Satin	518,00

## 71830

- Miscelatore monocomando per lavello con bocca alta tonda girevole.
- *Single-lever sink mixer with high round swivel spout.*
- Mitigeur monocommande évier avec bec haut rond pivotant .
- *Spültisch-Einhandbatterie mit hohem, rundem Schwenkauslauf.*
- Mezclador monomando para fregadero con caño alto redondo giratorio.



26849 25973

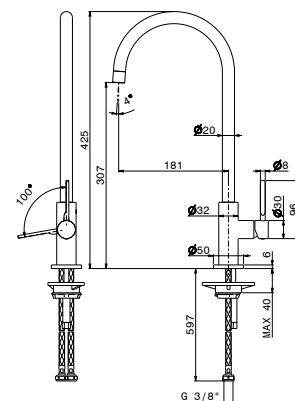

● 21.018	Chrome	295,00	● 59.066	PVD Br. Stainless Steel	635,00
● 01.093	Matt black	325,00	● 59.067	PVD Br. Copper Bronze	635,00
● 31.028	Brushed Nickel	335,00	● 59.098	PVD Br. Pale Gold	635,00
● 59.064	PVD Br. Gun Metal	635,00	● M0.077	Carbon Satin	395,00

## 71845

- Miscelatore monocomando per lavello con bocca tonda girevole e doccetta estraibile monogetto a scomparsa.
- Single-lever sink mixer, round swivel spout and single jet retractable pull-down hand shower.
- Mitigeur monocommande évier avec bec rond pivotant et douchette extractible retractable .
- Einhebel-Spültischmischer mit rundem Schwenkauslauf und ausziehbarer, versenkbarer Einstrahl-Handbrause.
- Mezclador monomando para fregadero con caño redondo giratorio y ducha extraíble monojet retráctil.

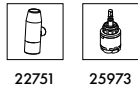

22751 25973

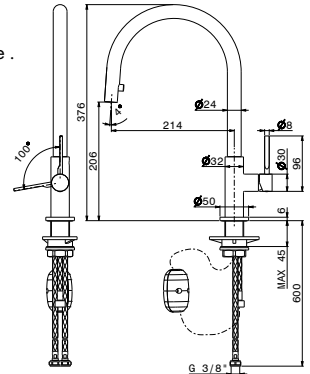

● 21.018	Chrome	363,00	● 59.066	PVD Br. Stainless Steel	720,00
● 01.093	Matt black	418,00	● 59.067	PVD Br. Copper Bronze	720,00
● 31.028	Brushed Nickel	425,00	● 59.098	PVD Br. Pale Gold	720,00
● 59.064	PVD Br. Gun Metal	720,00	● M0.077	Carbon Satin	483,00

## 71850

- Miscelatore monocomando per lavello con bocca tonda girevole e doccetta estraibile monogetto a scomparsa.
- Single-lever sink mixer, round swivel spout and single jet retractable pull-down hand shower.
- Mitigeur monocommande évier avec bec rond pivotant et douchette extractible retractable .
- Einhebel-Spültischmischer mit rundem Schwenkauslauf und ausziehbarer, versenkbarer Einstrahl-Handbrause.
- Mezclador monomando para fregadero con caño redondo giratorio y ducha extraíble monojet retráctil.

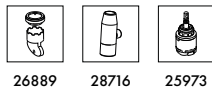

26889 28716 25973

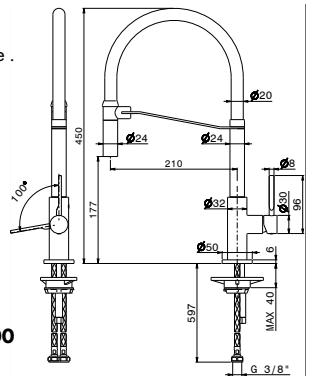

● 05.093	Chrome + Matt black	439,00	● 57.067	PVD Br. Copper Bronze + Matt black	799,00
● 01.093	Matt black	483,00	● 57.098	PVD Br. Pale Gold + Matt black	799,00
● 33.093	Brushed Nickel+M. black	479,00	● M2.077	Carbon Satin + M. black	499,00
● 57.064	PVD Br. Gun Metal + Matt black	799,00			
● 57.066	PVD Br. Stainless Steel + Matt black	799,00			

## 2418

- Dispenser per sapone liquido.
- Soap dispenser.
- Distributeur de savon .
- Flüssigseifenspender.
- Dispensador de jabón líquido.

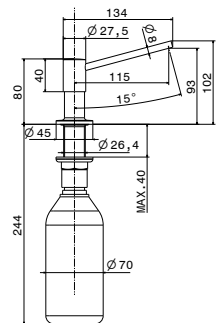

● 21.018	Chrome	159,00	● 59.066	PVD Br. Stainless Steel	251,00
● 01.093	Matt black	169,00	● 59.067	PVD Br. Copper Bronze	251,00
● 31.028	Brushed Nickel	204,00	● 59.098	PVD Br. Pale Gold	251,00
● 59.064	PVD Br. Gun Metal	251,00	● M0.077	Carbon Satin	203,00

Al momento dell'ordine del ricambio si prega di indicare il prodotto su cui dovrà essere installato al fine di determinare il modello corretto da fornire, comprensivo di eventuale tampografia.  
 When ordering the spare part, please specify the product it will be installed on, in order to determine the correct model to provide, including any required pad printing.

Lors de la commande de la pièce détachée, veuillez indiquer le produit sur lequel sera installée afin de déterminer le modèle correct à fournir, y compris toute tampographie éventuelle.

Bitte geben Sie bei der Bestellung des Ersatzteils das Produkt an, auf dem es installiert werden soll, um das richtige Modell einschließlich etwaiger Tampondrucke zu bestimmen.

Al realizar el pedido del repuesto, indique el producto en el que se instalará para determinar el modelo correcto a suministrar, incluyendo cualquier tampografía necesaria.

### 30870



- Maniglia completa per collezione MAKI.
- Complete handle for MAKI collection.
- Manette complète pour collection MAKI.
- Griff für die Küchenkollektion MAKI.
- Manija completa para colección MAKI.

● 21.018	Chrome	56,00
● 01.093	Matt black	67,00
● 31.028	Brushed Nickel	64,00
● 59.064	PVD Br. Gun Metal	143,00
● 59.066	PVD Br. Stainless Steel	143,00
● 59.067	PVD Br. Copper Bronze	143,00
● 59.098	PVD Br. Pale Gold	143,00
● M0.077	Carbon Satin	80,00

### 30705



- Doccetta per art.:
- Hand shower for art.:
- Douchette pour art.:
- Handbrause für Art.-Nr.:
- Ducha para art.:

#### 71825.

● 21.018	Chrome	56,00
● 01.093	Matt black	68,00
● 31.028	Brushed Nickel	68,00
● 59.064	PVD Br. Gun Metal	135,00
● 59.066	PVD Br. Stainless Steel	135,00
● 59.067	PVD Br. Copper Bronze	135,00
● 59.098	PVD Br. Pale Gold	135,00
● M0.077	Carbon Satin	79,00



### 24112



- Ghiera di fissaggio per cartuccia.
- Fixing plug for cartridge.
- Bouchon de fixation.
- Befestigungsring für Einhebel-Mischer.
- Anillo de fijación para cartucho.

● 21.018	Chrome	37,00
● 01.093	Matt black	43,00
● 31.028	Brushed Nickel	38,00
● 59.064	PVD Br. Gun Metal	48,00
● 59.066	PVD Br. Stainless Steel	48,00
● 59.067	PVD Br. Copper Bronze	48,00
● 59.098	PVD Br. Pale Gold	48,00
● M0.077	Carbon Satin	45,00

### 22751



- Doccetta per art.:
- Hand shower for art.:
- Douchette pour art.:
- Handbrause für Art.-Nr.:
- Ducha para art.:

#### 71845.

● 21.018	Chrome	54,00
● 01.093	Matt black	61,00
● 31.028	Brushed Nickel	69,00
● 59.064	PVD Br. Gun Metal	79,00
● 59.066	PVD Br. Stainless Steel	79,00
● 59.067	PVD Br. Copper Bronze	79,00
● 59.098	PVD Br. Pale Gold	79,00
● M0.077	Carbon Satin	59,00



### 25973



- Cartuccia a dischi ceramici.
- Cartridge with ceramic discs.
- Cartouche à disque céramique.
- Keramikscheibenkartusche.
- Cartucho de discos cerámicos.

○ 00.000	Neutral	49,00
----------	---------	-------

### 28716



- Doccetta per art.:
- Hand shower for art.:
- Douchette pour art.:
- Handbrause für Art.-Nr.:
- Ducha para art.:

#### 71850.

● 21.018	Chrome	68,00
● 01.093	Matt black	74,00
● 31.028	Brushed Nickel	77,00
● 59.064	PVD Br. Gun Metal	88,00
● 59.066	PVD Br. Stainless Steel	88,00
● 59.067	PVD Br. Copper Bronze	88,00
● 59.098	PVD Br. Pale Gold	88,00
● M0.077	Carbon Satin	81,00



# N21



**59.098** PVD BRUSHED PALE GOLD



**M0.077** CARBON SATIN



**59.064** PVD BRUSHED GUN METAL



**59.066** PVD BRUSHED STAINLESS STEEL



**59.067** PVD BRUSHED COPPER BRONZE



**21.018** CROMO / CHROME



**01.093** NERO OPACO / MATT BLACK



**31.028** NICKEL SPAZZOLATO  
BRUSHED NICKEL



## 71730

- Set per lavello composto da miscelatore monocomando, bocca tonda girevole e doccetta "sidespray".
- Complete set consisting of single-lever sink mixer, round swivel spout and "sidespray" shower hand.
- Set évier avec mitigeur monocommande, bec rond pivotant et douchette "sidespray".
- Spülbeckenset bestehend aus Einhebelmischer, rundem Auslauf schwenkbare "sidespray".
- Conjunto de fregadero compuesto por mezclador monomando, caño redondo giratorio y ducha "sidespray".

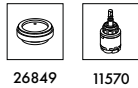

26849 11570

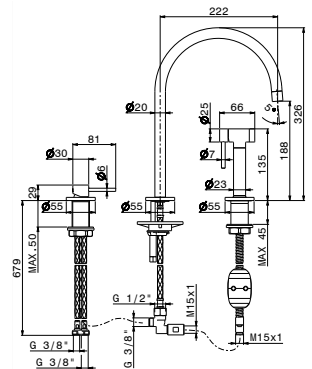

● 21.018	Chrome	588,00	● 59.066	PVD Br. Stainless Steel	1.089,00
● 01.093	Matt black	699,00	● 59.067	PVD Br. Copper Bronze	1.089,00
● 31.028	Brushed Nickel	639,00	● 59.098	PVD Br. Pale Gold	1.089,00
● 59.064	PVD Br. Gun Metal	1.089,00	● M0.077	Carbon Satin	739,00

## 71720

- Set per lavello composto da miscelatore monocomando e bocca L girevole.
- Complete set consisting of single-lever sink mixer and L swivel spout.
- Set évier avec mitigeur monocommande et bec L pivotant.
- Spülbeckenset bestehend aus Einhebelmischer und drehbarem L-Auslauf.
- Set para fregadero compuesto por mezclador monomando y caño con forma de L giratorio.



26882 11570

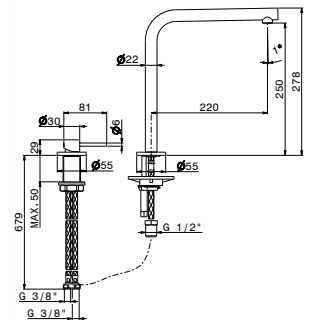

● 21.018	Chrome	329,00	● 59.066	PVD Br. Stainless Steel	655,00
● 01.093	Matt black	395,00	● 59.067	PVD Br. Copper Bronze	655,00
● 31.028	Brushed Nickel	391,00	● 59.098	PVD Br. Pale Gold	655,00
● 59.064	PVD Br. Gun Metal	655,00	● M0.077	Carbon Satin	434,00

## 71721

- Set per lavello composto da miscelatore monocomando e bocca tonda girevole.
- Complete set consisting of single-lever sink mixer and round swivel spout.
- Set évier avec mitigeur monocommande et bec rond pivotant.
- Spülbeckenset bestehend aus Einhebelmischer, rundem Auslauf schwenkbare.
- Set para fregadero compuesto por mezclador monomando y caño redondo giratorio.



26849 11570

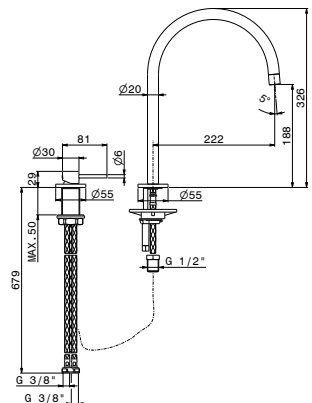

● 21.018	Chrome	369,00	● 59.066	PVD Br. Stainless Steel	735,00
● 01.093	Matt black	442,00	● 59.067	PVD Br. Copper Bronze	735,00
● 31.028	Brushed Nickel	439,00	● 59.098	PVD Br. Pale Gold	735,00
● 59.064	PVD Br. Gun Metal	735,00	● M0.077	Carbon Satin	479,00



Al momento dell'ordine del ricambio si prega di indicare il prodotto su cui dovrà essere installato al fine di determinare il modello corretto da fornire, comprensivo di eventuale tampografia.  
 When ordering the spare part, please specify the product it will be installed on, in order to determine the correct model to provide, including any required pad printing.

Lors de la commande de la pièce détachée, veuillez indiquer le produit sur lequel sera installée afin de déterminer le modèle correct à fournir, y compris toute tampographie éventuelle.

Bitte geben Sie bei der Bestellung des Ersatzteils das Produkt an, auf dem es installiert werden soll, um das richtige Modell einschließlich etwaiger Tampondrucke zu bestimmen.

Al realizar el pedido del repuesto, indique el producto en el que se instalará para determinar el modelo correcto a suministrar, incluyendo cualquier tampografía necesaria.

N21

### 30770



- Maniglia completa per collezione N21.
- Complete handle for N21 collection.
- Manette complète pour collection N21.
- Griff für die Küchenkollektion N21.
- Manija completa para colección N21.

● 21.018	Chrome	54,00
● 01.093	Matt black	66,00
● 31.028	Brushed Nickel	68,00
● 59.064	PVD Br. Gun Metal	115,00
● 59.066	PVD Br. Stainless Steel	115,00
● 59.067	PVD Br. Copper Bronze	115,00
● 59.098	PVD Br. Pale Gold	115,00
● M0.077	Carbon Satin	86,00

### 17964



- Doccetta "sidespray" per art.:
- "Sidespray" hand shower for art.:
- Douchette "sidespray" pour art.:
- "Sidespray" Handbrause für Art.-Nr.:
- Ducha "sidespray" para art.:

71730, 71731.

● 21.018	Chrome	159,00
● 01.093	Matt black	169,00
● 31.028	Brushed Nickel	173,00
● 59.064	PVD Br. Gun Metal	259,00
● 59.066	PVD Br. Stainless Steel	259,00
● 59.067	PVD Br. Copper Bronze	259,00
● 59.098	PVD Br. Pale Gold	259,00
● M0.077	Carbon Satin	189,00

### 24112



- Ghiera di fissaggio per cartuccia.
- Fixing plug for cartridge.
- Bouchon de fixation.
- Befestigungsring für Einhebel-Mischer.
- Anilla de fijación para cartucho.

● 21.018	Chrome	37,00
● 01.093	Matt black	43,00
● 31.028	Brushed Nickel	38,00
● 59.064	PVD Br. Gun Metal	48,00
● 59.066	PVD Br. Stainless Steel	48,00
● 59.067	PVD Br. Copper Bronze	48,00
● 59.098	PVD Br. Pale Gold	48,00
● M0.077	Carbon Satin	45,00

### 30705



- Doccetta per art.:
- Hand shower for art.:
- Douchette pour art.:
- Handbrause für Art.-Nr.:
- Ducha para art.:

71725.

● 21.018	Chrome	56,00
● 01.093	Matt black	68,00
● 31.028	Brushed Nickel	68,00
● 59.064	PVD Br. Gun Metal	135,00
● 59.066	PVD Br. Stainless Steel	135,00
● 59.067	PVD Br. Copper Bronze	135,00
● 59.098	PVD Br. Pale Gold	135,00
● M0.077	Carbon Satin	79,00



### 11570



- Cartuccia a dischi ceramici.
- Cartridge with ceramic discs.
- Cartouche à disque céramique.
- Keramikscheibenkartusche.
- Cartucho de discos cerámicos.

○ 00.000	Neutral	42,00
----------	---------	-------



# O'RAMA



**M2.077** CARBON SATIN  
MATT BLACK



**57.064** PVD BRUSHED GUN METAL  
MATT BLACK



**new**

**57.066** PVD BRUSHED STAINLESS STEEL  
MATT BLACK



**57.067** PVD BRUSHED COPPER BRONZE  
MATT BLACK



**05.093** CHROME / MATT BLACK



**01.093** NERO OPACO / MATT BLACK



**33.093** BRUSHED NICKEL / MATT BLACK

FULL STYLE



## 68735

- Miscelatore monocomando **semiprofessionale** per lavello con bocca girevole e orientabile. Erogazione a **doppio getto**.
- **Semi-professional** single-lever sink mixer with swivel and adjustable spout. **Double-jet** flow.
- Mitigeur monocomande évier **semi-professionnel** avec bec pivotant et orientable. **Double jet**.
- **Semiprofessioneller** Spültisch-Einhandbatterie mit schwenkbarem und verstellbarem Auslauf. **Doppelstrahl**-Auslauf.
- Mezclador monomando **semiprofessional** para fregadero con boca giratoria y orientable. Dispensación de **doble chorro**.



26817 13371 28725 25925

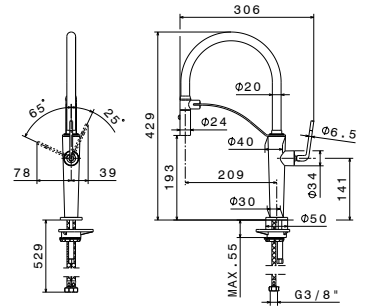

- |  |               |  |               |
|--|---------------|--|---------------|
| ● <b>05.093</b> Chrome + Matt black            | <b>579,00</b> | ● <b>57.066</b> PVD Br. Stainless Steel + Matt black | <b>849,00</b> |
| ● <b>01.093</b> Matt black                     | <b>649,00</b> | ● <b>57.067</b> PVD Br. Copper Bronze + Matt black   | <b>849,00</b> |
| ● <b>33.093</b> Brushed Nickel+M. black        | <b>618,00</b> | ● <b>M2.077</b> Carbon Satin + M. black              | <b>758,00</b> |
| ● <b>57.064</b> PVD Br. Gun Metal + Matt black | <b>849,00</b> |  |               |

## 2418

- Dispenser per sapone liquido.
- *Soap dispenser.*
- Distributeur de savon .
- Flüssigseifenspender.
- Dispensador de jabón líquido.

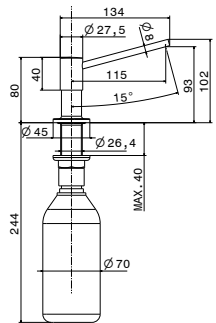

- |                                   |               |   |               |
|-----------------------------------|---------------|---|---------------|
| ● <b>21.018</b> Chrome            | <b>159,00</b> | ● <b>59.066</b> PVD Br. Stainless Steel | <b>251,00</b> |
| ● <b>01.093</b> Matt black        | <b>169,00</b> | ● <b>59.067</b> PVD Br. Copper Bronze   | <b>251,00</b> |
| ● <b>31.028</b> Brushed Nickel    | <b>204,00</b> | ● <b>M0.077</b> Carbon Satin            | <b>203,00</b> |
| ● <b>59.064</b> PVD Br. Gun Metal | <b>251,00</b> |   |               |

RICAMBI / SPARE PARTS / PIÈCES DÉTACHÉES / ERSATZTEILE / REPUESTOS

Al momento dell'ordine del ricambio si prega di indicare il prodotto su cui dovrà essere installato al fine di determinare il modello corretto da fornire, comprensivo di eventuale tampografia.  
 When ordering the spare part, please specify the product it will be installed on, in order to determine the correct model to provide, including any required pad printing.

Lors de la commande de la pièce détachée, veuillez indiquer le produit sur lequel sera installée afin de déterminer le modèle correct à fournir, y compris toute tampographie éventuelle.  
 Bitte geben Sie bei der Bestellung des Ersatzteils das Produkt an, auf dem es installiert werden soll, um das richtige Modell einschließlich etwaiger Tampondrucke zu bestimmen.

Al realizar el pedido del repuesto, indique el producto en el que se instalará para determinar el modelo correcto a suministrar, incluyendo cualquier tampografía necesaria.

**28770**



- Maniglia completa per collezione O'RAMA.
- Complete handle for O'RAMA collection.
- Manette complète pour collection O'RAMA.
- Griff für die Küchenkollektion O'RAMA.
- Manija completa para colección O'RAMA.

● <b>05.093</b>	Chrome + Matt black	<b>58,00</b>
● <b>01.093</b>	Matt black	<b>62,00</b>
● <b>33.093</b>	Brushed Nickel+M. black	<b>64,00</b>
● <b>57.064</b>	PVD Br. Gun Metal +Matt black	<b>69,00</b>
● <b>57.066</b>	PVD Br. Stainless Seel +Matt black	<b>69,00</b>
● <b>57.067</b>	PVD Br. Copper Bronze +Matt black	<b>69,00</b>
● <b>M2.077</b>	Carbon Satin + M. black	<b>67,00</b>

**28725**



- Doccetta a doppio getto per art.:
- Double-jet hand shower for art.:
- Douchette double jet pour art.:
- Doppelstrahl-Handbrause für Art.-Nr.:
- Ducha de doble chorro para art.:

**68735.**

● <b>21.018</b>	Chrome	<b>99,00</b>
● <b>01.093</b>	Matt black	<b>111,00</b>
● <b>31.028</b>	Brushed Nickel	<b>115,00</b>
● <b>59.064</b>	PVD Br. Gun Metal	<b>140,00</b>
● <b>59.066</b>	PVD Br. Stainless Seel	<b>140,00</b>
● <b>59.067</b>	PVD Br. Copper Bronze	<b>140,00</b>
● <b>M0.077</b>	Carbon Satin	<b>130,00</b>



**25925**



- Cartuccia a dischi ceramici.
- Cartridge with ceramic discs.
- Cartouche à disque céramique.
- Keramikscheibenkartusche.
- Cartucho de discos cerámicos.

○ <b>00.000</b>	Neutral	<b>53,00</b>
-----------------	---------	--------------

# LIBERA



**59.067** PVD BRUSHED COPPER BRONZE



**M2.077** CARBON SATIN  
MATT BLACK



**31.028** NICKEL SPAZZOLATO  
BRUSHED NICKEL



**59.064** PVD BRUSHED GUN METAL



**59.066** PVD BRUSHED STAINLESS STEEL



**21.018** CROMO / CHROME



**01.093** NERO OPACO / MATT BLACK



**05.093** CHROME / MATT BLACK

FULL STYLE



LIBERA



### 63930

- Miscelatore monocomando per lavello con molla girevole e orientabile. **Erogazione a doppio getto.**
- Single-lever sink mixer with swivel and adjustable spring. **Double-jet flow.**
- Mitigeur monocommande évier avec ressort pivotant et orientable **double jet**.
- Einhebel-Spültischmischer mit Drehgelenk und einstellbarer Feder. **Doppelstrahl-Auslauf.**
- Mezclador monomando para fregadero con muelle giratorio y orientable. **Dispensación de doble chorro.**

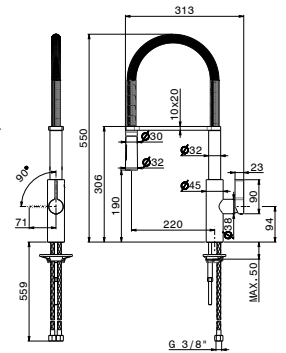

● 21.018	Chrome	696,00	● 59.064	PVD Br. Gun Metal	1.155,00
● 01.093	Matt black	751,00	● 59.066	PVD Br. Stainless Steel	1.155,00
● 05.093	Chrome + Matt black	730,00	● 59.067	PVD Br. Copper Bronze	1.155,00
● 31.028	Brushed Nickel	870,00	● M0.077	Carbon Satin	918,00

### 63915

- Miscelatore monocomando per lavello con bocca L girevole e doccetta estraibile a doppio getto.
- Single-lever sink mixer with L swivel spout and **double-jet** pull-out hand shower.
- Mitigeur monocommande évier avec bec L pivotant et douchette extractible **double jet**.
- Einhebel-Spültischmischer mit drehbarem L-Auslauf und ausziehbarer **Doppelstrahl-Handbrause**.
- Mezclador monomando para fregadero con caño con forma de L giratorio y ducha extraíble de **doble chorro**.

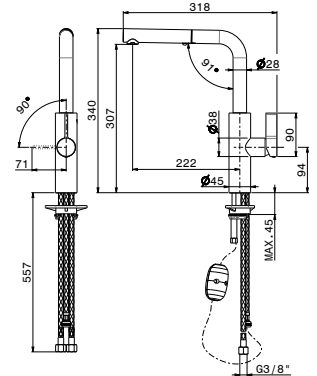
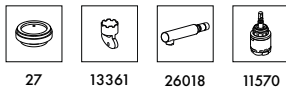

● 21.018	Chrome	569,00	● 59.066	PVD Br. Stainless Steel	967,00
● 01.093	Matt black	672,00	● 59.067	PVD Br. Copper Bronze	967,00
● 31.028	Brushed Nickel	685,00	● M0.077	Carbon Satin	823,00
● 59.064	PVD Br. Gun Metal	967,00			

### 2418

- Dispenser per sapone liquido.
- Soap dispenser.
- Distributeur de savon.
- Flüssigseifenspender.
- Dispensador de jabón líquido.

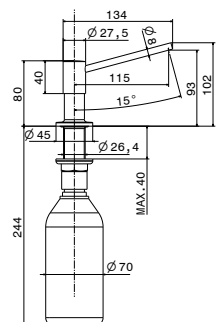

● 21.018	Chrome	169,00	● 59.066	PVD Br. Stainless Steel	251,00
● 01.093	Matt black	159,00	● 59.067	PVD Br. Copper Bronze	251,00
● 31.028	Brushed Nickel	204,00	● M0.077	Carbon Satin	203,00
● 59.064	PVD Br. Gun Metal	251,00			

Al momento dell'ordine del ricambio si prega di indicare il prodotto su cui dovrà essere installato al fine di determinare il modello corretto da fornire, comprensivo di eventuale tampografia.  
 When ordering the spare part, please specify the product it will be installed on, in order to determine the correct model to provide, including any required pad printing.  
 Lors de la commande de la pièce détachée, veuillez indiquer le produit sur lequel sera installée afin de déterminer le modèle correct à fournir, y compris toute tampographie éventuelle.  
 Bitte geben Sie bei der Bestellung des Ersatzteils das Produkt an, auf dem es installiert werden soll, um das richtige Modell einschließlich etwaiger Tampondrucke zu bestimmen.  
 Al realizar el pedido del repuesto, indique el producto en el que se instalará para determinar el modelo correcto a suministrar, incluyendo cualquier tampografía necesaria.

## 24873

- Maniglia completa per collezione LIBERA.
- Complete handle for LIBERA collection.
- Manette complète pour collection LIBERA.
- Griff für die Küchenkollektion LIBERA.
- Manija completa para colección LIBERA.



● 21.018	Chrome	47,00
● 01.093	Matt black	57,00
● 31.028	Brushed Nickel	61,00
● 59.064	PVD Br. Gun Metal	92,00
● 59.066	PVD Br. Stainless Steel	92,00
● 59.067	PVD Br. Copper Bronze	92,00
● M0.077	Carbon Satin	68,00

## 26011

- Doccetta doppio getto per art.:
- Double jet hand shower for art.:
- Douchette double jet pour art.:
- Doppelstrahl-Handbrause für Art.-Nr.:
- Ducha de doble chorro para art.



63930.

● 21.018	Chrome	93,00
● 01.093	Matt black	105,00
● 31.028	Brushed Nickel	119,00
● 59.064	PVD Br. Gun Metal	149,00
● 59.066	PVD Br. Stainless Steel	149,00
● 59.067	PVD Br. Copper Bronze	149,00
● M0.077	Carbon Satin	114,00



## 26000

- Ghiera di fissaggio per cartuccia collezione LIBERA.
- Fixing ring nut for cartridge LIBERA collection.
- Écrou de fixation pour cartouche collection LIBERA.
- Befestigungsring für Kartusche der Küchenkollektion LIBERA.
- Anilla de fijación para cartucho colección LIBERA.



● 21.018	Chrome	38,00
● 01.093	Matt black	46,00
● 31.028	Brushed Nickel	48,00
● 59.064	PVD Br. Gun Metal	55,00
● 59.066	PVD Br. Stainless Steel	55,00
● 59.067	PVD Br. Copper Bronze	55,00
● M0.077	Carbon Satin	52,00

## 26018

- Doccetta doppio getto per art.:
- Double jet hand shower for art.:
- Douchette double jet art.:
- Doppelstrahl-Handbrause für Art.-Nr.:
- Ducha de doble chorro para art.:



63915.

● 21.018	Chrome	119,00
● 01.093	Matt black	155,00
● 31.028	Brushed Nickel	149,00
● 59.064	PVD Br. Gun Metal	177,00
● 59.066	PVD Br. Stainless Steel	177,00
● 59.067	PVD Br. Copper Bronze	177,00
● M0.077	Carbon Satin	174,00



## 11570

- Cartuccia a dischi ceramici.
- Cartridge with ceramic discs.
- Cartouche à disque céramique.
- Keramikscheibenkartusche.
- Cartucho de discos cerámicos.



○ 00.000	Neutral	42,00
----------	---------	-------

# ERGO

FULL STYLE



**21.018** CROMO / CHROME





## 65910

- Miscelatore monocomando per lavello con bocca girevole.
- *Single-lever sink mixer with swivel spout.*
- Mitigeur monocommande évier avec bec pivotant .
- *Einhebel-Spültischmischer mit drehbarem Auslauf.*
- Mezclador monomando para fregadero con caño giratorio.



59



14720

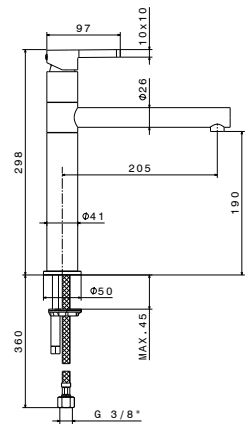

● 21.018 Chrome

297,00



## 65915

- Miscelatore monocomando per lavello con bocca girevole e doccetta estraibile.
- *Single-lever sink mixer with swivel spout and pull-out hand shower.*
- Mitigeur monocommande évier avec bec pivotant et douchette extractible .
- *Einhebel- Küchenmischer mit Schwenkauslauf, Ausziehbrause.*
- Mezclador monomando para fregadero con caño giratorio y ducha extraíble.



91



16113



14720

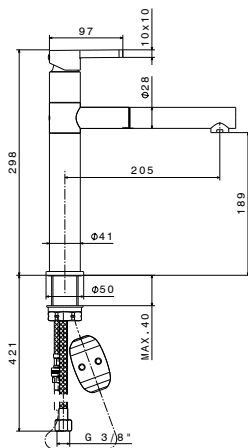

● 21.018 Chrome

390,00



## 65920

- Miscelatore monocomando per lavello con bocca quadra girevole.
- *Single-lever sink mixer with squared swivel spout.*
- Mitigeur monocommande évier avec bec carré pivotant .
- *Einhebel-Spültischmischer mit quadratischem Schwenkauslauf.*
- Mezclador monomando para fregadero con caño cuadrado giratorio.



26849



25922

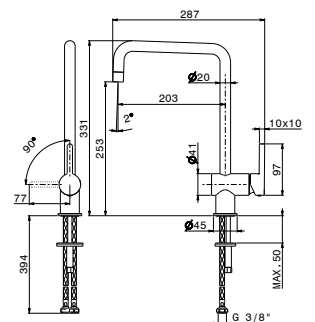

● 21.018 Chrome

244,00



## 65921

- Miscelatore monocomando per lavello con bocca tonda girevole.
- *Single-lever sink mixer with round swivel spout.*
- Mitigeur monocommande évier avec bec rond pivotant .
- Einhebel-Spültischmischer mit rundem Schwenkauslauf.
- Mezclador monomando para fregadero con caño redondo giratorio.



26849



25922

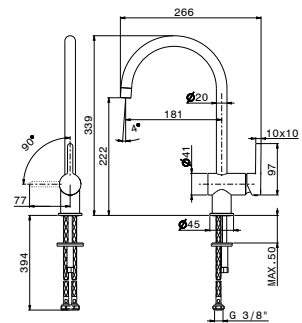

● 21.018 Chrome

244,00



## 65925

- Miscelatore monocomando per lavello con bocca girevole e doccetta estraibile a doppio getto.
- *Single-lever sink mixer with swivel spout and double-jet pull-out hand shower.*
- Mitigeur monocommande évier avec bec pivotant et douchette extractible double jet .
- Einhebel- Küchenmischer mit Schwenkauslauf, Ausziehbrause, 2jet.
- Mezclador monomando para fregadero con caño giratorio y ducha extraíble de doble chorro.



16755



25117



25922

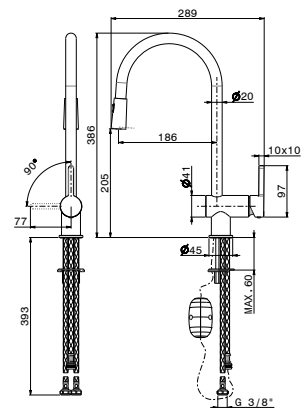

● 21.018 Chrome

347,00

## 2418

- Dispenser per sapone liquido.
- *Soap dispenser.*
- Distributeur de savon .
- Flüssigseifenspender.
- Dispensador de jabón líquido.

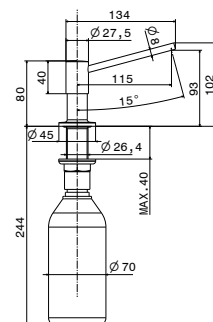

● 21.018 Chrome

159,00

Al momento dell'ordine del ricambio si prega di indicare il prodotto su cui dovrà essere installato al fine di determinare il modello corretto da fornire, comprensivo di eventuale tampografia.  
 When ordering the spare part, please specify the product it will be installed on, in order to determine the correct model to provide, including any required pad printing.  
 Lors de la commande de la pièce détachée, veuillez indiquer le produit sur lequel sera installée afin de déterminer le modèle correct à fournir, y compris toute tampographie éventuelle.  
 Bitte geben Sie bei der Bestellung des Ersatzteils das Produkt an, auf dem es installiert werden soll, um das richtige Modell einschließlich etwaiger Tampondrucke zu bestimmen.  
 Al realizar el pedido del repuesto, indique el producto en el que se instalará para determinar el modelo correcto a suministrar, incluyendo cualquier tampografía necesaria.

## 25070

- Maniglia per art.:
- Handle for art.:
- Manette pour art.:
- Griff für art.:
- Manija para art.:

65910, 65915.



● 21.018 Chrome 49,00

## 25179

- Maniglia per art.:
- Handle for art.:
- Manette pour art.:
- Griff für art.:
- Manija para art.:

65920, 65921, 65925.



● 21.018 Chrome 43,00

## 25228

- Cappuccio coprighiera per collezione ERGO.
- Cover ring nut cap for ERGO collection.
- Cache écrou couvre-joint pour collection ERGO.
- Ringkappe für die Küchenkollektion ERGO.
- Embellecedor de anilla para colección ERGO.



● 21.018 Chrome 27,00

## 25227

- Ghiera di fissaggio per cartuccia collezione ERGO.
- Fixing ring nut for cartridge ERGO collection.
- Écrou de fixation pour cartouche collection ERGO.
- Befestigungsring für Kartusche der Küchenkollektion ERGO.
- Anilla de fijación para cartucho colección ERGO.



○ 00.000 Neutral 28,00

## 14720

- Cartuccia a dischi ceramici per art.:
- Cartridge with ceramic discs for art.:
- Cartouche à disque céramique pour art.:
- Keramikscheibenkartusche für Art.-Nr.:
- Cartucho de discos cerámicos para art.:

65910, 65915.



○ 00.000 Neutral 37,00

## 25922

- Cartuccia a dischi ceramici per art.:
- Cartridge with ceramic discs for art.:
- Cartouche à disque céramique pour art.:
- Keramikscheibenkartusche für Art.-Nr.:
- Cartucho de discos cerámicos para art.:

65920, 65921, 65925.



○ 00.000 Neutral 44,00

RICAMBI / SPARE PARTS / PIÈCES DÉTACHÉES / ERSATZTEILE / REPUESTOS

Al momento dell'ordine del ricambio si prega di indicare il prodotto su cui dovrà essere installato al fine di determinare il modello corretto da fornire, comprensivo di eventuale tampografia.

*When ordering the spare part, please specify the product it will be installed on, in order to determine the correct model to provide, including any required pad printing.*

Lors de la commande de la pièce détachée, veuillez indiquer le produit sur lequel sera installée afin de déterminer le modèle correct à fournir, y compris toute tampographie éventuelle.

*Bitte geben Sie bei der Bestellung des Ersatzteils das Produkt an, auf dem es installiert werden soll, um das richtige Modell einschließlich etwaiger Tampondrucke zu bestimmen.*

Al realizar el pedido del repuesto, indique el producto en el que se instalará para determinar el modelo correcto a suministrar, incluyendo cualquier tampografía necesaria.

**16113**

- Doccetta per art.:
- Hand shower for art.:
- Douchette pour art.:
- Handbrause für Art.-Nr.:
- Ducha para art.:

**65915.**



**25117**

- Doccetta **doppio getto** per art.:
- **Double jet** hand shower for art.:
- Douchette **double jet** art.:
- **Doppelstrahl**-Handbrause für Art.-Nr.:
- Ducha de **doble chorro** para art.:

**65925.**



● **21.018** Chrome **69,00**

● **21.018** Chrome **84,00**

# YCON



**59.067** PVD BRUSHED COPPER BRONZE



**59.098** PVD BRUSHED PALE GOLD



**M0.077** CARBON SATIN



**31.028** BRUSHED NICKEL



**59.064** PVD BRUSHED GUN METAL



**new**  
**59.066** PVD BRUSHED STAINLESS STEEL



**21.018** CROMO / CHROME



**01.093** NERO OPACO / MATT BLACK



**01.014** BIANCO OPACO / MATT WHITE

FULL STYLE





## 64200

- Miscelatore monocomando per lavello con bocca tonda girevole.
- *Single-lever sink mixer with round swivel spout.*
- Mitigeur monocommande évier avec bec rond pivotant .
- *Einhebel-Spültischmischer mit rundem Schwenkauslauf.*
- Mezclador monomando para fregadero con caño redondo giratorio.

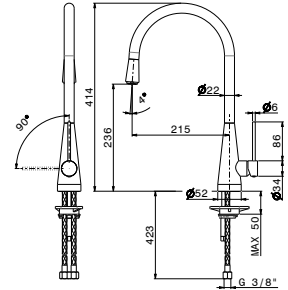
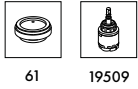

● 21.018	Chrome	415,00	● 59.066	PVD Br. Stainless Steel	795,00
● 01.014	Matt white	443,00	● 59.067	PVD Br. Copper Bronze	795,00
● 01.093	Matt black	443,00	● 59.098	PVD Br. Pale Gold	795,00
● 31.028	Brushed Nickel	495,00	● M0.077	Carbon Satin	589,00
● 59.064	PVD Br. Gun Metal	795,00			

## 64215

- Miscelatore monocomando per lavello con bocca tonda girevole e doccetta estraibile monogetto.
- *Single-lever sink mixer, round swivel spout and single jet pull-out hand shower.*
- Mitigeur monocommande évier avec bec rond pivotant et douchette extractible monojet.
- *Einhebel-Spültischarmatur mit schwenkbarem Rundauslauf und herausziehbarer Einstrahlbrause.*
- Mezclador monomando para fregadero con caño redondo giratorio y ducha extraíble monojet.

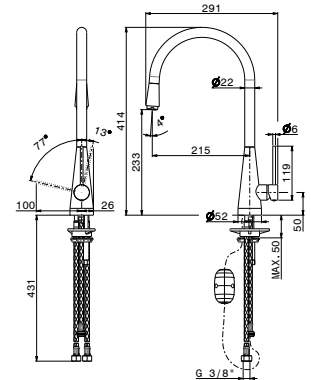
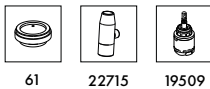

● 21.018	Chrome	489,00	● 59.066	PVD Br. Stainless Steel	859,00
● 01.014	Matt white	549,00	● 59.067	PVD Br. Copper Bronze	859,00
● 01.093	Matt black	549,00	● 59.098	PVD Br. Pale Gold	859,00
● 31.028	Brushed Nickel	545,00	● M0.077	Carbon Satin	670,00
● 59.064	PVD Br. Gun Metal	859,00			

## 64213

- Miscelatore monocomando per lavello con bocca tonda girevole e doccetta estraibile monogetto a scomparsa.
- *Single-lever sink mixer, round swivel spout and single jet retractable pull-out hand shower.*
- Mitigeur monocommande évier avec bec rond pivotant et douchette extractible retractable .
- *Einhebel-Spültischmischer mit rundem Schwenkauslauf und ausziehbarer, versenkbarer Einstrahl-Handbrause.*
- Mezclador monomando para fregadero con caño redondo giratorio y ducha extraíble monofunciónretráctil.

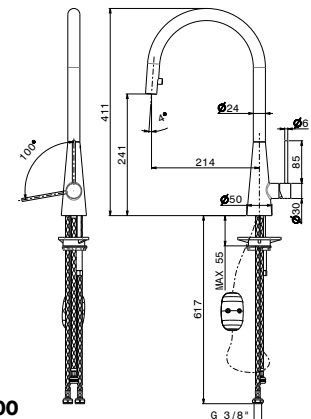
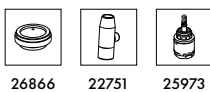

● 21.018	Chrome	390,00	● 59.066	PVD Br. Stainless Steel	849,00
● 01.014	Matt white	440,00	● 59.067	PVD Br. Copper Bronze	849,00
● 01.093	Matt black	440,00	● 59.098	PVD Br. Pale Gold	849,00
● 31.028	Brushed Nickel	462,00	● M0.077	Carbon Satin	495,00
● 59.064	PVD Br. Gun Metal	849,00			



## 2418

- Dispenser per sapone liquido.
- Soap dispenser.
- Distributeur de savon .
- Flüssigseifenspender.
- Dispensador de jabón líquido.

● <b>21.018</b>	Chrome	<b>159,00</b>	● <b>59.066</b>	PVD Br. Stainless Seel	<b>251,00</b>
● <b>01.014</b>	Matt white	<b>169,00</b>	● <b>59.067</b>	PVD Br. Copper Bronze	<b>251,00</b>
● <b>01.093</b>	Matt black	<b>169,00</b>	● <b>59.098</b>	PVD Br. Pale Gold	<b>251,00</b>
● <b>31.028</b>	Brushed Nickel	<b>204,00</b>	● <b>M0.077</b>	Carbon Satin	<b>203,00</b>
● <b>59.064</b>	PVD Br. Gun Metal	<b>251,00</b>			

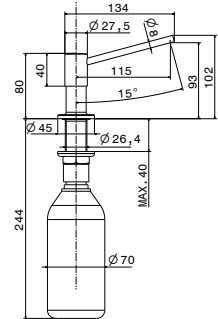

Al momento dell'ordine del ricambio si prega di indicare il prodotto su cui dovrà essere installato al fine di determinare il modello corretto da fornire, comprensivo di eventuale tampografia.  
 When ordering the spare part, please specify the product it will be installed on, in order to determine the correct model to provide, including any required pad printing.

Lors de la commande de la pièce détachée, veuillez indiquer le produit sur lequel sera installée afin de déterminer le modèle correct à fournir, y compris toute tampographie éventuelle.

Bitte geben Sie bei der Bestellung des Ersatzteils das Produkt an, auf dem es installiert werden soll, um das richtige Modell einschließlich etwaiger Tampondrucke zu bestimmen.

Al realizar el pedido del repuesto, indique el producto en el que se instalará para determinar el modelo correcto a suministrar, incluyendo cualquier tampografía necesaria.

## 22777



- Maniglia per art.:
- Handle for art.:
- Manette pour art.:
- Griff für art.:
- Manija para art.:

**64200, 64215.**

● 21.018	Chrome	<b>58,00</b>
● 01.014	Matt white	<b>72,00</b>
● 01.093	Matt black	<b>72,00</b>
● 31.028	Brushed Nickel	<b>73,00</b>
● 59.064	PVD Br. Gun Metal	<b>109,00</b>
● 59.066	PVD Br. Stainless Steel	<b>109,00</b>
● 59.067	PVD Br. Copper Bronze	<b>109,00</b>
● 59.098	PVD Br. Pale Gold	<b>109,00</b>
● MO.077	Carbon Satin	<b>99,00</b>

## 22778



- Maniglia per art.:
- Handle for art.:
- Manette pour art.:
- Griff für art.:
- Manija para art.:

**64213.**

● 21.018	Chrome	<b>58,00</b>
● 01.014	Matt white	<b>72,00</b>
● 01.093	Matt black	<b>72,00</b>
● 31.028	Brushed Nickel	<b>73,00</b>
● 59.064	PVD Br. Gun Metal	<b>109,00</b>
● 59.066	PVD Br. Stainless Steel	<b>109,00</b>
● 59.067	PVD Br. Copper Bronze	<b>109,00</b>
● 59.098	PVD Br. Pale Gold	<b>109,00</b>
● MO.077	Carbon Satin	<b>99,00</b>

## 24112



- Ghiera di fissaggio cartuccia per art.:
- Fixing ring nut for art.:
- Bouchon de fixation pour cartouche pour art.:
- Kartuschenbefestigungs-Ringmutter für Art.-Nr.:
- Anilla de fijación de cartucho para art.:

**64213.**

● 21.018	Chrome	<b>37,00</b>
● 01.014	Matt white	<b>43,00</b>
● 01.093	Matt black	<b>43,00</b>
● 31.028	Brushed Nickel	<b>38,00</b>
● 59.064	PVD Br. Gun Metal	<b>48,00</b>
● 59.066	PVD Br. Stainless Steel	<b>48,00</b>
● 59.067	PVD Br. Copper Bronze	<b>48,00</b>
● 59.098	PVD Br. Pale Gold	<b>48,00</b>
● MO.077	Carbon Satin	<b>45,00</b>

## 22601



- Ghiera di fissaggio cartuccia per art.:
- Fixing ring nut for art.:
- Bouchon de fixation pour cartouche pour art.:
- Kartuschenbefestigungs-Ringmutter für Art.-Nr.:
- Anilla de fijación de cartucho para art.:

**64200, 64215.**

● 21.018	Chrome	<b>42,00</b>
● 01.014	Matt white	<b>51,00</b>
● 01.093	Matt black	<b>51,00</b>
● 31.028	Brushed Nickel	<b>51,00</b>
● 59.064	PVD Br. Gun Metal	<b>71,00</b>
● 59.066	PVD Br. Stainless Steel	<b>71,00</b>
● 59.067	PVD Br. Copper Bronze	<b>71,00</b>
● 59.098	PVD Br. Pale Gold	<b>71,00</b>
● MO.077	Carbon Satin	<b>61,00</b>

## 19509



- Cartuccia a dischi ceramici per art.:
- Cartridge with ceramic discs for art.:
- Cartouche à disque céramique pour art.:
- Keramikscheibenkartusche für Art.-Nr.:
- Cartucho de discos cerámicos para art.:

**64200, 64215.**

○ 00.000	Neutral	<b>48,00</b>
----------	---------	--------------

## 25973



- Cartuccia a dischi ceramici per art.:
- Cartridge with ceramic discs for art.:
- Cartouche à disque céramique pour art.:
- Keramikscheibenkartusche für Art.-Nr.:
- Cartucho de discos cerámicos para art.:

**64213.**

○ 00.000	Neutral	<b>49,00</b>
----------	---------	--------------

RICAMBI / SPARE PARTS / PIÈCES DÉTACHÉES / ERSATZTEILE / REPUESTOS

Al momento dell'ordine del ricambio si prega di indicare il prodotto su cui dovrà essere installato al fine di determinare il modello corretto da fornire, comprensivo di eventuale tampografia.

*When ordering the spare part, please specify the product it will be installed on, in order to determine the correct model to provide, including any required pad printing.*

Lors de la commande de la pièce détachée, veuillez indiquer le produit sur lequel sera installée afin de déterminer le modèle correct à fournir, y compris toute tampographie éventuelle.

*Bitte geben Sie bei der Bestellung des Ersatzteils das Produkt an, auf dem es installiert werden soll, um das richtige Modell einschließlich etwaiger Tampondrucke zu bestimmen.*

Al realizar el pedido del repuesto, indique el producto en el que se instalará para determinar el modelo correcto a suministrar, incluyendo cualquier tampografía necesaria.

## 22715

- Doccetta completa per art. 64215 completa di flessibile in Nylon.
- Complete hand shower for art. 64215 with Nylon hose.
- Douchette pour art. 64215 avec flexible en Nylon.
- Komplette Handbrause für Art.-Nr. 64215 komplett mit Nylonschlauch.
- Ducha completa para art. 64215 con flexible de nailon.



● 21.018	Chrome	95,00
● 01.014	Matt white	99,00
● 01.093	Matt black	99,00
● 31.028	Brushed Nickel	101,00
● 59.064	PVD Br. Gun Metal	121,00
● 59.066	PVD Br. Stainless Steel	121,00
● 59.067	PVD Br. Copper Bronze	121,00
● 59.098	PVD Br. Pale Gold	121,00
● M0.077	Carbon Satin	108,00



## 22751

- Doccetta per art.:
- Hand shower for art.:
- Douchette pour art.:
- Handbrause für Art.-Nr.:
- Ducha para art.:

**64213.**



● 21.018	Chrome	54,00
● 01.014	Matt white	61,00
● 01.093	Matt black	61,00
● 31.028	Brushed Nickel	69,00
● 59.064	PVD Br. Gun Metal	79,00
● 59.066	PVD Br. Stainless Steel	79,00
● 59.067	PVD Br. Copper Bronze	79,00
● 59.098	PVD Br. Pale Gold	79,00
● M0.077	Carbon Satin	59,00



# MOONY



**MO.077** CARBON SATIN



**59.064** PVD BRUSHED GUN METAL



**new**

**59.066** PVD BRUSHED STAINLESS STEEL



**59.067** PVD BRUSHED COPPER BRONZE



**21.018** CROMO / CHROME



**01.093** NERO OPACO / MATT BLACK



**31.028** NICKEL SPAZZOLATO  
BRUSHED NICKEL

FULL STYLE



## 3100

- Miscelatore monocomando per lavello con bocca L girevole e **terminale orientabile**.
- *Single-lever sink mixer with L swivel spout and **adjustable outlet**.*
- Mitigeur monocommande évier avec bec L pivotant et **orientable**.
- *Einhebel-Spültischmischer mit drehbarem L-Auslauf und **verstellbarem Anschluss**.*
- Mezclador monomando para fregadero con caño con forma de L giratorio y **terminal orientable**.

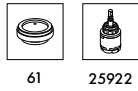

61 25922

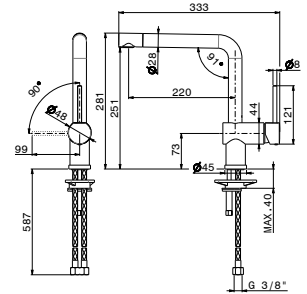

● 21.018	Chrome	439,00	● 59.066	PVD Br. Stainless Steel	757,00
● 01.093	Matt black	465,00	● 59.067	PVD Br. Copper Bronze	757,00
● 31.028	Brushed Nickel	545,00	● M0.077	Carbon Satin	595,00
● 59.064	PVD Br. Gun Metal	757,00			

## 3101

- Miscelatore monocomando per lavello con bocca L girevole con **doppia uscita** per acqua depurata. **Depuratore non incluso**.
- *Single-lever sink mixer, L swivel spout with **double outlet** for purified water. **Purifier not included**.*
- Mitigeur monocommande évier avec bec L pivotant . **Deux sorties** pour eau purifiée . **Purificateur non inclus** .
- *Einhebel-Spültischmischer mit drehbarem L-Auslauf und **doppeltem Auslauf** für gereinigtes Wasser. **Luftreiniger nicht im Lieferumfang enthalten**.*
- Mezclador monomando para fregadero con caño con forma de L giratorio con **doble salida** para agua purificada. **Purificador no incluido**.



59 25922 25943

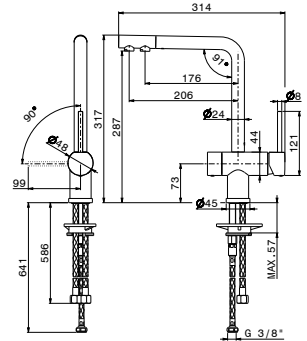

● 21.018	Chrome	625,00	● 59.066	PVD Br. Stainless Steel	1.014,00
● 01.093	Matt black	694,00	● 59.067	PVD Br. Copper Bronze	1.014,00
● 31.028	Brushed Nickel	726,00	● M0.077	Carbon Satin	838,00
● 59.064	PVD Br. Gun Metal	1.014,00			

## 3103 new

- Miscelatore monocomando per lavello con bocca L girevole con doppia uscita per acqua depurata. **Comprensivo di Cartuccia filtrante AQA drink AC 100**.
- *Single-lever sink mixer with L swivel spout and double outlet for purified water. **Complete with AQA drink AC 100 filter cartridge**.*
- Mitigeur monocommande évier avec bec L pivotant avec double sortie pour eau épurée . **Avec cartouche filtrante AQA drink AC 100** .
- *Einhebel-Spültischmischer mit schwenkbarem L-Auslauf mit doppeltem Wasserauslauf für gereinigtes Wasser. **Inklusive Filterkartusche AQA drink AC 100**.*
- Mezclador monomando para fregadero con caño con forma de L giratorio con doble salida para agua purificada. **Incluye cartucho filtrante AQA drink AC 100**.



59 25922 25943

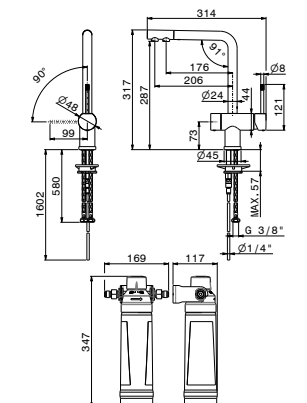

● 21.018	Chrome	860,00	● 59.066	PVD Br. Stainless Steel	1.249,00
● 01.093	Matt black	929,00	● 59.067	PVD Br. Copper Bronze	1.249,00
● 31.028	Brushed Nickel	961,00	● M0.077	Carbon Satin	1.073,00
● 59.064	PVD Br. Gun Metal	1.249,00			



## 3155



- Miscelatore monocomando professionale per lavello monoforo, con doppia bocca girevole e doccetta "sidespray". Modello depositato.
- Professional single-lever mixer for 1-hole sink, with two swivel spouts and "sidespray" hand shower. Patent pending.
- Mitigeur monocommande évier professionnel avec double bec pivotant et douchette "sidespray". Breveté.
- Professioneller Einhebelmischer für Einlochspüle, mit doppeltem Schwenkauslauf und Handbrause "sidespray". Registriertes Modell.
- Mezclador monomando profesional para fregadero de agujeros único, con doble caño giratorio y ducha "sidespray". Modelo registrado.

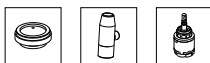

26872 18314 25922

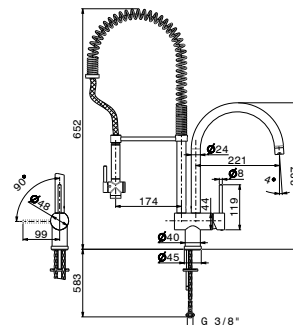

● 21.018	Chrome	1.099,00	● 59.066	PVD Br. Stainless Steel	1.680,00
● 01.093	Matt black	1.135,00	● 59.067	PVD Br. Copper Bronze	1.680,00
● 31.028	Brushed Nickel	1.299,00	● M0.077	Carbon Satin	1.347,00
● 59.064	PVD Br. Gun Metal	1.680,00			

## 2418



- Dispenser per sapone liquido.
- Soap dispenser.
- Distributeur de savon.
- Flüssigseifenspender.
- Dispensador de jabón líquido.

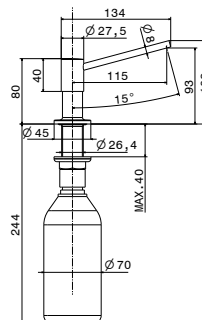

● 21.018	Chrome	159,00	● 59.066	PVD Br. Stainless Steel	251,00
● 01.093	Matt black	169,00	● 59.067	PVD Br. Copper Bronze	251,00
● 31.028	Brushed Nickel	204,00	● M0.077	Carbon Satin	203,00
● 59.064	PVD Br. Gun Metal	251,00			

Al momento dell'ordine del ricambio si prega di indicare il prodotto su cui dovrà essere installato al fine di determinare il modello corretto da fornire, comprensivo di eventuale tampografia.  
 When ordering the spare part, please specify the product it will be installed on, in order to determine the correct model to provide, including any required pad printing.

Lors de la commande de la pièce détachée, veuillez indiquer le produit sur lequel sera installée afin de déterminer le modèle correct à fournir, y compris toute tampographie éventuelle.

Bitte geben Sie bei der Bestellung des Ersatzteils das Produkt an, auf dem es installiert werden soll, um das richtige Modell einschließlich etwaiger Tampondrucke zu bestimmen.

Al realizar el pedido del repuesto, indique el producto en el que se instalará para determinar el modelo correcto a suministrar, incluyendo cualquier tampografía necesaria.

## 18350

- Maniglia per art.:
- Handle for art.:
- Manette pour art.:
- Griff für art.:
- Manija para art.:

3140.



● 21.018	Chrome	66,00
● 01.093	Matt black	84,00
● 31.028	Brushed Nickel	89,00
● 59.064	PVD Br. Gun Metal	115,00
● 59.066	PVD Br. Stainless Steel	115,00
● 59.067	PVD Br. Copper Bronze	115,00
● M0.077	Carbon Satin	111,00

## 18357

- Maniglia per art.:
- Handle for art.:
- Manette pour art.:
- Griff für art.:
- Manija para art.:

3100, 3101, 3103, 3110, 3125, 3155.



● 21.018	Chrome	66,00
● 01.093	Matt black	84,00
● 31.028	Brushed Nickel	89,00
● 59.064	PVD Br. Gun Metal	115,00
● 59.066	PVD Br. Stainless Steel	115,00
● 59.067	PVD Br. Copper Bronze	115,00
● M0.077	Carbon Satin	111,00

## 16801

- Ghiera di fissaggio per cartuccia.
- Fixing plug for cartridge.
- Bouchon de fixation.
- Befestigungsring für Einhebel-Mischer.
- Anilla de fijación para cartucho.



● 21.018	Chrome	45,00
● 01.093	Matt black	51,00
● 31.028	Brushed Nickel	53,00
● 59.064	PVD Br. Gun Metal	63,00
● 59.066	PVD Br. Stainless Steel	63,00
● 59.067	PVD Br. Copper Bronze	63,00
● M0.077	Carbon Satin	59,00

## 25922

- Cartuccia a dischi ceramici per art.:
- Cartridge with ceramic discs for art.:
- Cartouche à disque céramique pour art.:
- Keramikscheibenkartusche für Art.-Nr.:
- Cartucho de discos cerámicos para art.:

3100, 3101, 3103, 3110, 3125, 3155.



○ 00.000	Neutral	44,00
----------	---------	-------

## 14720

- Cartuccia a dischi ceramici per art.:
- Cartridge with ceramic discs for art.:
- Cartouche à disque céramique pour art.:
- Keramikscheibenkartusche für Art.-Nr.:
- Cartucho de discos cerámicos para art.:

3140.



○ 00.000	Neutral	37,00
----------	---------	-------

## 25943

- Vitone a dischi ceramici 90° apertura antioraria per art.:
- Ceramic disks cartridge 90° counterclockwise opening for art.:
- Têtes à disques céramiques 90° ouverture sens antihoraire pour art.:
- Seitenventil, Keramikoberteil 90° entgegen Uhrzeigersinn Öffnung für Art.-Nr.:
- Mando discos cerámicos 90° apertura en sentido antihorario para art.:

3101, 3103.



○ 00.000	Neutral	44,00
----------	---------	-------

Al momento dell'ordine del ricambio si prega di indicare il prodotto su cui dovrà essere installato al fine di determinare il modello corretto da fornire, comprensivo di eventuale tampografia.  
 When ordering the spare part, please specify the product it will be installed on, in order to determine the correct model to provide, including any required pad printing.

Lors de la commande de la pièce détachée, veuillez indiquer le produit sur lequel sera installée afin de déterminer le modèle correct à fournir, y compris toute tampographie éventuelle.  
 Bitte geben Sie bei der Bestellung des Ersatzteils das Produkt an, auf dem es installiert werden soll, um das richtige Modell einschließlich etwaiger Tampondrucke zu bestimmen.

Al realizar el pedido del repuesto, indique el producto en el que se instalará para determinar el modelo correcto a suministrar, incluyendo cualquier tampografía necesaria.

## 16113



- Doccetta per art.:
- Hand shower for art.:
- Douchette pour art.:
- Handbrause für Art.-Nr.:
- Ducha para art.:

3110.

● 21.018	Chrome	<b>69,00</b>
● 01.093	Matt black	<b>79,00</b>
● 31.028	Brushed Nickel	<b>83,00</b>
● 59.064	PVD Br. Gun Metal	<b>116,00</b>
● 59.066	PVD Br. Stainless Steel	<b>116,00</b>
● 59.067	PVD Br. Copper Bronze	<b>116,00</b>
● M0.077	Carbon Satin	<b>107,00</b>

## 32403



- Testata AQA drink MMW.
- AQA drink MMW nozzle.
- Tête AQA drink MMW.
- Zylinderkopf AQA-Drink MMW.
- Cabezal AQA drink MMW.

○ 00.000 Neutral **117,00**

## 18314



- Doccetta "sidespray" per art.:
- "Sidespray" hand shower for art.:
- Douchette "sidespray" pour art.:
- "Sidespray" Handbrause für Art.-Nr.:
- Ducha "sidespray" para art.:

3155.

● 21.018	Chrome	<b>184,00</b>
● 01.093	Matt black	<b>221,00</b>
● 31.028	Brushed Nickel	<b>241,00</b>
● 59.064	PVD Br. Gun Metal	<b>285,00</b>
● 59.066	PVD Br. Stainless Steel	<b>285,00</b>
● 59.067	PVD Br. Copper Bronze	<b>285,00</b>
● M0.077	Carbon Satin	<b>275,00</b>

## 32402



- Cartuccia filtrante AQA drink AC 100.
- AQA drink AC 100 filter cartridge.
- Cartouche filtrante AQA drink AC 100.
- Filterkartusche AQA Drink AC 100.
- Cartucho filtrante AQA drink AC 100.

○ 00.000 Neutral **137,00**

## 18056



- Doccetta completa di flessibile in PVC per art.:
- Complete hand shower with PVC hose for art.:
- Douchette avec flexible en PVC pour art.:
- Handbrause komplett mit PVC-Schlauch für Art.-Nr.:
- Ducha completa con flexible en PVC para art.:

3125.

● 21.018	Chrome	<b>89,00</b>
● 01.093	Matt black	<b>97,00</b>
● 31.028	Brushed Nickel	<b>103,00</b>
● 59.064	PVD Br. Gun Metal	<b>115,00</b>
● 59.066	PVD Br. Stainless Steel	<b>115,00</b>
● 59.067	PVD Br. Copper Bronze	<b>115,00</b>
● M0.077	Carbon Satin	<b>109,00</b>



# X-TREND

FULL STYLE



**21.018** CROMO / CHROME



**31.028** NICKEL SPAZZOLATO  
BRUSHED NICKEL



## 2400

- Miscelatore monocomando per lavello con bocca girevole e **terminale orientabile**
- *Single-lever sink mixer with swivel spout and **adjustable outlet**.*
- Mitigeur monocommande évier avec **bec pivotant et orientable**.
- Einhebel-Spültischmischer mit schwenkbarem Auslauf und **verstellbarem Anschluss**.
- Mezclador monomando para fregadero con caño giratorio y **terminal orientable**.

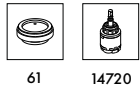

61

14720

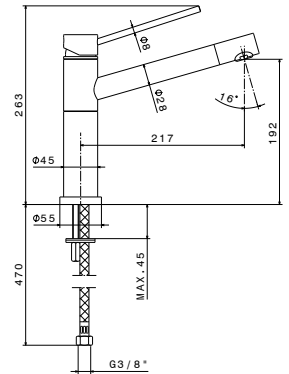

- **21.018** Chrome **383,00**
- **31.028** Brushed Nickel **475,00**

## 2415

- Miscelatore monocomando per lavello con bocca girevole e doccetta estraibile.
- *Single-lever sink mixer with swivel spout and **pull-out hand shower**.*
- Mitigeur monocommande évier avec bec pivotant et douchette extractible.
- Einhebel-Spültischmischer mit schwenkbarem Auslauf und **ausziehbarer Handbrause**.
- Mezclador monomando para fregadero con caño giratorio y ducha extraíble.

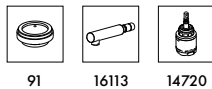

91

16113

14720

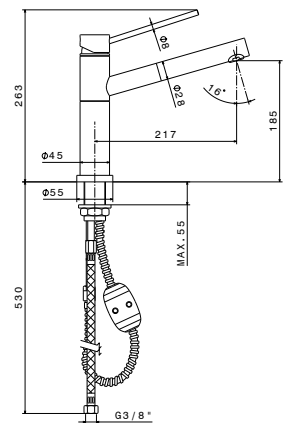

- **21.018** Chrome **460,00**
- **31.028** Brushed Nickel **573,00**

## 2439

- Gruppo miscelatore monocomando per lavello **con bocca abbattibile**.
- *Single-lever sink unit **with pull down spout**.*
- Mitigeur monocommande évier **avec bec rabattable**.
- Einhebelmischer-Set für Spüle **mit klappbarem Auslauf**.
- Grupo mezclador monomando para fregadero **con caño abatible**.

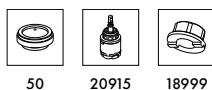

50

20915

18999

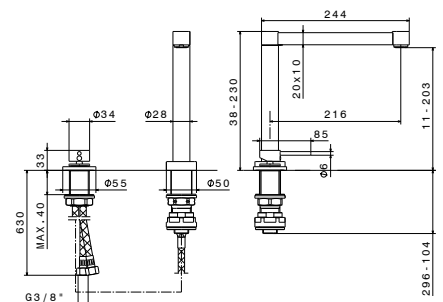

- **21.018** Chrome **733,00**
- **31.028** Brushed Nickel **915,00**

## 2260

- Rubinetto erogatore per acqua fredda, unica entrata.
- *One outlet, cold water tap.*
- Robinet eau froide, 1 entrée .
- Kaltwasserhahn mit Einzelloch.
- Grifo dispensador de agua fría, entrada única.



59



10237

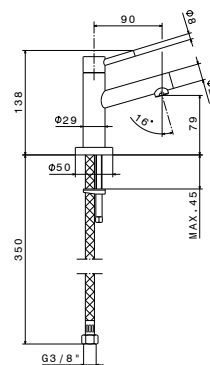

- **21.018** Chrome **189,00**
- **31.028** Brushed Nickel **232,00**

## 2418

- Dispenser per sapone liquido.
- *Soap dispenser.*
- Distributeur de savon .
- Flüssigseifenspender.
- Dispensador de jabón líquido.

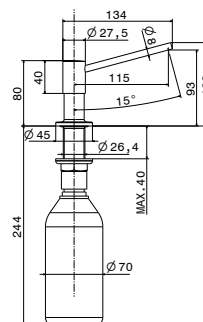

- **21.018** Chrome **159,00**
- **31.028** Brushed Nickel **204,00**

RICAMBI / SPARE PARTS / PIÈCES DÉTACHÉES / ERSATZTEILE / REPUESTOS

Al momento dell'ordine del ricambio si prega di indicare il prodotto su cui dovrà essere installato al fine di determinare il modello corretto da fornire, comprensivo di eventuale tampografia.  
 When ordering the spare part, please specify the product it will be installed on, in order to determine the correct model to provide, including any required pad printing.

Lors de la commande de la pièce détachée, veuillez indiquer le produit sur lequel sera installée afin de déterminer le modèle correct à fournir, y compris toute tampographie éventuelle.

Bitte geben Sie bei der Bestellung des Ersatzteils das Produkt an, auf dem es installiert werden soll, um das richtige Modell einschließlich etwaiger Tampondrucke zu bestimmen.

Al realizar el pedido del repuesto, indique el producto en el que se instalará para determinar el modelo correcto a suministrar, incluyendo cualquier tampografía necesaria.

**16123**

- Maniglia per art.:
- Handle for art.:
- Manette pour art.:
- Griff für art.:
- Manija para art.:

**2400, 2415.**



- **21.018** Chrome **55,00**
- **31.028** Brushed Nickel **74,00**

**10775**

- Maniglia per art.:
- Handle for art.:
- Manette pour art.:
- Griff für art.:
- Manija para art.:

**2439.**



- **21.018** Chrome **66,00**
- **31.028** Brushed Nickel **69,00**

**15938**

- Maniglia per art.:
- Handle for art.:
- Manette pour art.:
- Griff für art.:
- Manija para art.:

**2260.**



- **21.018** Chrome **58,00**
- **31.028** Brushed Nickel **63,00**

**16113**

- Doccetta per art.:
- Hand shower for art.:
- Douchette pour art.:
- Handbrause für Art.:
- Ducha para art. 2415.:

**2415.**



- **21.018** Chrome **69,00**
- **31.028** Brushed Nickel **83,00**

**19429**

- Ghiera di fissaggio per cartuccia art.:
- Fixing ring nut for cartridge art.:
- Bouchon de fixation pour cartouche pour art.:
- Kartuschenbefestigungs-Ringmutter für Art.-Nr.:
- Anilla de fijación para cartucho art.:

**2439.**



- **21.018** Chrome **50,00**
- **31.028** Brushed Nickel **52,00**

**16005**

- Ghiera di fissaggio per cartuccia art.:
- Fixing ring nut for cartridge art.:
- Bouchon de fixation pour cartouche pour art.:
- Kartuschenbefestigungs-Ringmutter für Art.-Nr.:
- Anilla de fijación para cartucho art.:

**2400, 2415.**



- **21.018** Chrome **46,00**
- **31.028** Brushed Nickel **51,00**

RICAMBI / SPARE PARTS / PIÈCES DÉTACHÉES / ERSATZTEILE / REPUESTOS

Al momento dell'ordine del ricambio si prega di indicare il prodotto su cui dovrà essere installato al fine di determinare il modello corretto da fornire, comprensivo di eventuale tampografia.  
 When ordering the spare part, please specify the product it will be installed on, in order to determine the correct model to provide, including any required pad printing.

Lors de la commande de la pièce détachée, veuillez indiquer le produit sur lequel sera installée afin de déterminer le modèle correct à fournir, y compris toute tampographie éventuelle.  
 Bitte geben Sie bei der Bestellung des Ersatzteils das Produkt an, auf dem es installiert werden soll, um das richtige Modell einschließlich etwaiger Tampondrucke zu bestimmen.

Al realizar el pedido del repuesto, indique el producto en el que se instalará para determinar el modelo correcto a suministrar, incluyendo cualquier tampografía necesaria.

**14720**

- Cartuccia a dischi ceramici per art.:
- Cartridge with ceramic discs for art.:
- Cartouche à disque céramique pour art.:
- Keramikscheibenkartusche für Art.-Nr.:
- Cartucho de discos cerámicos para art.:

**2400, 2415.**



○ 00.000 Neutral **37,00**

**20915**

- Cartuccia a dischi ceramici per art.:
- Cartridge with ceramic discs for art.:
- Cartouche à disque céramique pour art.:
- Keramikscheibenkartusche für Art.-Nr.:
- Cartucho de discos cerámicos para art.:

**2439.**



○ 00.000 Neutral **51,00**

# REAL



**59.064** PVD BRUSHED GUN METAL



**59.067** PVD BRUSHED COPPER BRONZE



**59.098** PVD BRUSHED PALE GOLD



**21.018** CROMO / CHROME



**31.028** NICKEL SPAZZOLATO  
BRUSHED NICKEL



**43.238** ANTRACITE  
ANTHRACITE

FULL STYLE



## 63420

- Miscelatore monocomando per lavello con bocca quadra girevole.
- *Single-lever sink mixer with squared swivel spout.*
- Mitigeur monocommande évier avec bec carré pivotant .
- Einhebel-Spültischmischer mit quadratischem Schwenkauslauf.
- Mezclador monomando para fregadero con caño cuadrado giratorio.



26811 25922

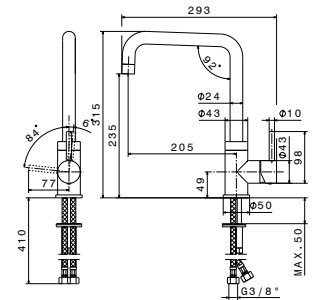

● 21.018	Chrome	271,00	● 59.064	PVD Br. Gun Metal	361,00
● 31.028	Brushed Nickel	296,00	● 59.067	PVD Br. Copper Bronze	361,00
● 43.238	Anthracite	274,00	● 59.098	PVD Br. Pale Gold	361,00

## 63421

- Miscelatore monocomando per lavello con bocca tonda girevole.
- *Single-lever sink mixer with round swivel spout.*
- Mitigeur monocommande évier avec bec rond pivotant .
- Einhebel-Spültischmischer mit rundem Schwenkauslauf.
- Mezclador monomando para fregadero con caño redondo giratorio.



26811 25922

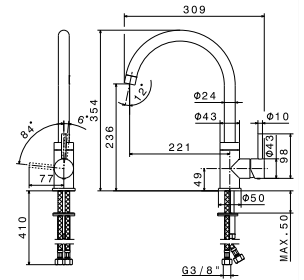

● 21.018	Chrome	259,00	● 59.064	PVD Br. Gun Metal	366,00
● 31.028	Brushed Nickel	291,00	● 59.067	PVD Br. Copper Bronze	366,00
● 43.238	Anthracite	268,00	● 59.098	PVD Br. Pale Gold	366,00

## 63425

- Miscelatore monocomando per lavello con bocca L girevole e doccetta estraibile.
- *Single-lever sink mixer with L swivel spout and pull-out hand shower.*
- Mitigeur monocommande évier avec bec L pivotant et douchette extractible .
- Einhebel-Spültischmischer mit schwenkbarem L-Auslauf und ausziehbarer Handbrause.
- Mezclador monomando para fregadero con caño con forma de L giratorio y ducha extraíble.

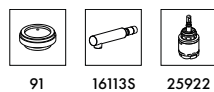

91 16113S 25922

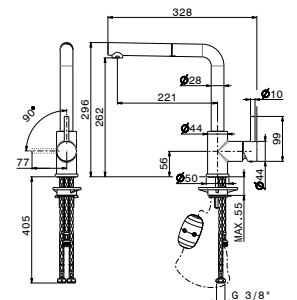

● 21.018	Chrome	325,00	● 59.064	PVD Br. Gun Metal	529,00
● 31.028	Brushed Nickel	377,00	● 59.067	PVD Br. Copper Bronze	529,00
● 43.238	Anthracite	426,00	● 59.098	PVD Br. Pale Gold	529,00



## 2418

- Dispenser per sapone liquido.
- Soap dispenser.
- Distributeur de savon .
- Flüssigseifenspender.
- Dispensador de jabón líquido.

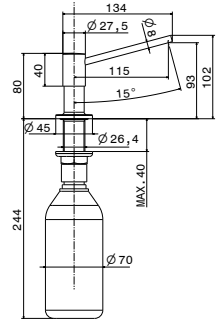

● 21.018	Chrome	<b>159,00</b>	● 59.064	PVD Br. Gun Metal	<b>251,00</b>
● 31.028	Brushed Nickel	<b>204,00</b>	● 59.067	PVD Br. Copper Bronze	<b>251,00</b>
● 43.238	Anthracite	<b>184,00</b>	● 59.098	PVD Br. Pale Gold	<b>251,00</b>

Al momento dell'ordine del ricambio si prega di indicare il prodotto su cui dovrà essere installato al fine di determinare il modello corretto da fornire, comprensivo di eventuale tampografia.  
 When ordering the spare part, please specify the product it will be installed on, in order to determine the correct model to provide, including any required pad printing.

Lors de la commande de la pièce détachée, veuillez indiquer le produit sur lequel sera installée afin de déterminer le modèle correct à fournir, y compris toute tampographie éventuelle.

Bitte geben Sie bei der Bestellung des Ersatzteils das Produkt an, auf dem es installiert werden soll, um das richtige Modell einschließlich etwaiger Tampondrucke zu bestimmen.

Al realizar el pedido del repuesto, indique el producto en el que se instalará para determinar el modelo correcto a suministrar, incluyendo cualquier tampografía necesaria.

## 24695



- Maniglia completa per collezione REAL.
- Complete handle for REAL collection.
- Manette complète pour collection REAL.
- Griff für die Küchenkollektion REAL.
- Manija completa para colección REAL.

● 21.018	Chrome	47,00
● 31.028	Brushed Nickel	51,00
● 43.238	Anthracite	54,00
● 59.064	PVD Br. Gun Metal	74,00
● 59.067	PVD Br. Copper Bronze	74,00
● 59.098	PVD Br. Pale Gold	74,00

## 16113S



- Doccetta per art.:
- Hand shower for art.:
- Douchette pour art.:
- Handbrause für Art.-Nr.:
- Ducha para art.:

**63425.**

● 21.018	Chrome	69,00
● 31.028	Brushed Nickel	83,00
● 43.238	Anthracite	79,00
● 59.064	PVD Br. Gun Metal	116,00
● 59.067	PVD Br. Copper Bronze	116,00
● 59.098	PVD Br. Pale Gold	116,00

## 25922



- Cartuccia a dischi ceramici.
- Cartridge with ceramic discs.
- Cartouche à disque céramique.
- Keramikscheibenkartusche.
- Cartucho de discos cerámicos.

○ 00.000	Neutral	44,00
----------	---------	-------

## 24613



- Ghiera di fissaggio per cartuccia.
- Fixing plug for cartridge.
- Bouchon de fixation.
- Befestigungsring für Einhebel-Mischer.
- Anilla de fijación para cartucho.

○ 00.000	Neutral	29,00
----------	---------	-------

## 24612



- Cappuccio coprihiera in ABS collezione REAL cucina.
- ABS cover ring nut cap for REAL kitchen collection.
- Cache écrou couvre-joint en ABS collection REAL.
- Ringkappe aus ABS für REAL Küchenkollektion.
- Embellecedor de anilla en ABS colección REAL cocina.

● 21.018	Chrome	27,00
● 31.028	Brushed Nickel	29,00
● 43.238	Anthracite	35,00
● 59.064	PVD Br. Gun Metal	47,00
● 59.067	PVD Br. Copper Bronze	47,00
● 59.098	PVD Br. Pale Gold	47,00



# XT

FULL STYLE



**21.018** CROMO / CHROME



**01.093** NERO OPACO / MATT BLACK



**31.028** NICKEL SPAZZOLATO  
BRUSHED NICKEL



## 4319

- Miscelatore monocomando per lavello con bocca L girevole.
- *Single-lever sink mixer with L swivel spout.*
- Mitigeur monocommande évier avec bec L pivotant .
- Einhebel-Spültischmischer mit drehbarem L-Auslauf.
- Mezclador monomando para fregadero con caño con forma de L giratorio.



13301 26882 25922

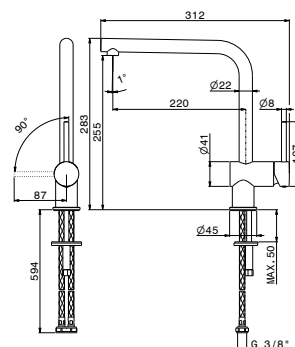

● 21.018	Chrome	<b>280,00</b>
● 01.093	Matt black	<b>325,00</b>
● 31.028	Brushed Nickel	<b>305,00</b>

## 4320

- Miscelatore monocomando per lavello con bocca quadra girevole.
- *Single-lever sink mixer, squared swivel spout.*
- Mitigeur monocommande évier avec bec carré pivotant .
- Einhebel-Spültischmischer mit quadratischem Schwenkauslauf.
- Mezclador monomando para fregadero con caño cuadrado giratorio.



26849 25922

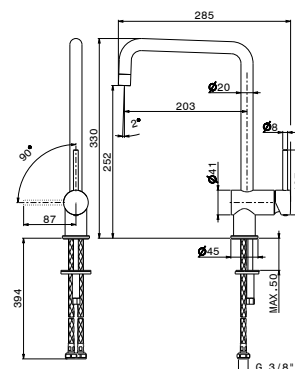

● 21.018	Chrome	<b>228,00</b>
● 01.093	Matt black	<b>321,00</b>
● 31.028	Brushed Nickel	<b>294,00</b>

## 4325

- Miscelatore monocomando per lavello con bocca tonda girevole.
- *Single-lever sink mixer, round swivel spout.*
- Mitigeur monocommande évier avec bec rond pivotant .
- Spültisch-Einhandbatterie mit rundem Schwenkauslauf.
- Mezclador monomando para fregadero con caño redondo giratorio.



26849 25922

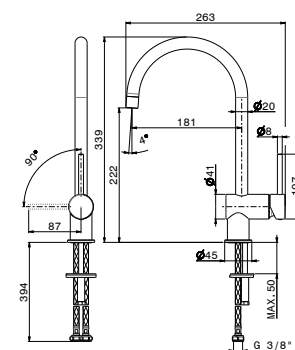

● 21.018	Chrome	<b>228,00</b>
● 01.093	Matt black	<b>321,00</b>
● 31.028	Brushed Nickel	<b>294,00</b>



## 4371

- Miscelatore monocomando per lavello con bocca tonda girevole **reclinabile** per sotto finestra.
- Single-lever sink mixer with swivel, **reclining** and round spout for under window.
- Mitigeur monocommande évier avec bec rond pivotant et **rabattable**.
- Einhebel- Küchenmischer mit rundem Schwenkauslauf, **Vorfenstermontage**.
- Mezclador monomando para fregadero con caño redondo giratorio **reclinable** para debajo de ventana.



26849



25922

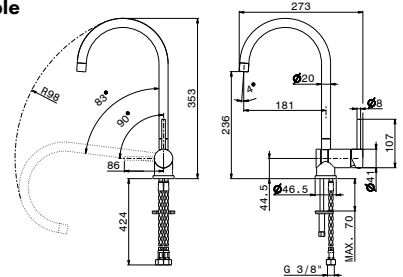

● 21.018	Chrome	<b>391,00</b>
● 01.093	Matt black	<b>450,00</b>
● 31.028	Brushed Nickel	<b>470,00</b>

## 2418

- Dispenser per sapone liquido.
- Soap dispenser.
- Distributeur de savon .
- Flüssigseifenspender.
- Dispensador de jabón líquido.

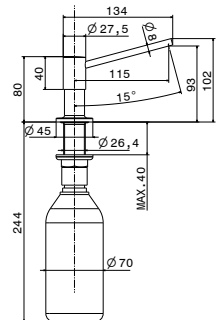

● 21.018	Chrome	<b>159,00</b>
● 01.093	Matt black	<b>169,00</b>
● 31.028	Brushed Nickel	<b>204,00</b>

Al momento dell'ordine del ricambio si prega di indicare il prodotto su cui dovrà essere installato al fine di determinare il modello corretto da fornire, comprensivo di eventuale tampografia.  
 When ordering the spare part, please specify the product it will be installed on, in order to determine the correct model to provide, including any required pad printing.

Lors de la commande de la pièce détachée, veuillez indiquer le produit sur lequel sera installée afin de déterminer le modèle correct à fournir, y compris toute tampographie éventuelle.

Bitte geben Sie bei der Bestellung des Ersatzteils das Produkt an, auf dem es installiert werden soll, um das richtige Modell einschließlich etwaiger Tampondrucke zu bestimmen.

Al realizar el pedido del repuesto, indique el producto en el que se instalará para determinar el modelo correcto a suministrar, incluyendo cualquier tampografía necesaria.

## 19254



- Maniglia completa per collezione XT.
- Complete handle for XT collection.
- Manette complète pour collection XT.
- Griff für die Küchenkollektion XT.
- Manija completa para colección XT.

● 21.018	Chrome	54,00
● 01.093	Matt black	56,00
● 31.028	Brushed Nickel	68,00

## 25922



- Cartuccia a dischi ceramici.
- Cartridge with ceramic discs.
- Cartouche à disque céramique.
- Keramikscheibenkartusche.
- Cartucho de discos cerámicos.

○ 00.000	Neutral	44,00
----------	---------	-------

## 25228



- Cappuccio coprighiera per collezione XT.
- Cover ring nut cap for XT collection.
- Cache écrou couvre-joint pour collection XT.
- Ringkappe für die Küchenkollektion XT.
- Embellecedor de anilla para colección XT.

● 21.018	Chrome	27,00
● 01.093	Matt black	35,00
● 31.028	Brushed Nickel	39,00

## 25227



- Ghiera di fissaggio per cartuccia collezione XT.
- Fixing ring nut for cartridge XT collection.
- Écrou de fixation pour cartouche collection XT.
- Befestigungsring für Kartusche der Küchenkollektion XT.
- Anilla de fijación para cartucho colección XT.

○ 00.000	Neutral	28,00
----------	---------	-------

## 17432



- Doccetta completa per art. 4345 completa di flessibile in Nylon.
- Complete hand shower for art. 4345 with Nylon hose.
- Douchette pour art. 4345 avec flexible en Nylon.
- Komplette Handbrause für Art.-Nr. 4345 komplett mit Nylonschlauch.
- Ducha completa para art. 4345 con flexible de nailon.

● 21.018	Chrome	79,00
● 01.093	Matt black	86,00
● 31.028	Brushed Nickel	95,00

## 30705



- Doccetta per art.:
- Hand shower for art.:
- Douchette pour art.:
- Handbrause für Art.-Nr.:
- Ducha para art.:

**4340.**

● 21.018	Chrome	56,00
● 01.093	Matt black	68,00
● 31.028	Brushed Nickel	68,00



# MARVEL

FULL STYLE



**21.018** CROMO / CHROME



**31.028** NICKEL SPAZZOLATO  
BRUSHED NICKEL



**new**

**47.083** GROOVE BRONZE



## 8550

- Miscelatore monocomando per lavello con bocca girevole in stile "retro".
- Single-lever sink mixer, tubular swivel "retro" style spout.
- Mitigeur monocommande évier avec bec pivotant style rétro .
- Spültisch-Einhandbatterie mit schwenkbarem Auslauf im „Retro“-Stil.
- Mezclador monomando para fregadero con caño giratorio en estilo "retro".

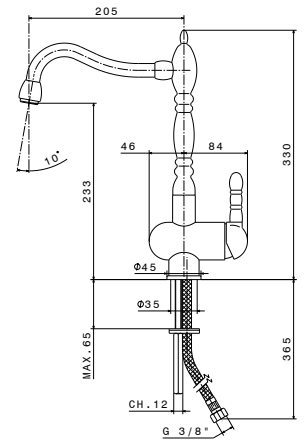
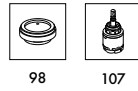

● 21.018	Chrome	<b>486,00</b>
● 31.028	Brushed Nickel	<b>581,00</b>
● 47.083	Groove bronze	<b>743,00</b>

## 8650

- Miscelatore monocomando per lavello con bocca in stile "retro" girevole e reclinabile per sotto finestra.
- Single-lever sink mixer, with swivel and reclining "retro" style spout.
- Mitigeur monocommande évier avec bec pivotant rabattable style rétro .
- Einhand-Spültischmischer mit Drehgelenk im „Retro“-Stil und verstellbarem Auslauf, Vorfenstermontage.
- Mezclador monomando para fregadero con caño en estilo "retro" giratorio y reclinable para debajo de ventana.

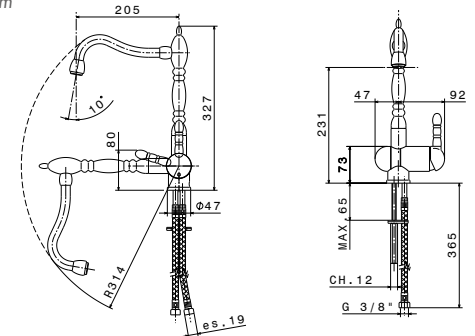
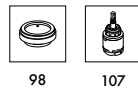

● 21.018	Chrome	<b>584,00</b>
● 31.028	Brushed Nickel	<b>664,00</b>
● 47.083	Groove bronze	<b>751,00</b>

Al momento dell'ordine del ricambio si prega di indicare il prodotto su cui dovrà essere installato al fine di determinare il modello corretto da fornire, comprensivo di eventuale tampografia.  
 When ordering the spare part, please specify the product it will be installed on, in order to determine the correct model to provide, including any required pad printing.

Lors de la commande de la pièce détachée, veuillez indiquer le produit sur lequel sera installée afin de déterminer le modèle correct à fournir, y compris toute tampographie éventuelle.

Bitte geben Sie bei der Bestellung des Ersatzteils das Produkt an, auf dem es installiert werden soll, um das richtige Modell einschließlich etwaiger Tampondrucke zu bestimmen.

Al realizar el pedido del repuesto, indique el producto en el que se instalará para determinar el modelo correcto a suministrar, incluyendo cualquier tampografía necesaria.

## 14026



- Maniglia completa collezione MARVEL per art. con canna "retro".
- Complete handle for MARVEL collection for art. with "retro" style spout.
- Manette pour collection MARVEL pour art. style rétro.
- Komplette Griff-Kollektion MARVEL für Art. mit „Retro“-Lauf.
- Manija completa colección MARVEL para art. con caño "retro".

● 21.018	Chrome	<b>63,00</b>
● 31.028	Brushed Nickel	<b>85,00</b>
● 47.083	Groove bronze	<b>85,00</b>

## 107



- Cartuccia a dischi ceramici.
- Cartridge with ceramic discs.
- Cartouche à disque céramique.
- Keramikscheibenkartusche.
- Cartucho de discos cerámicos.

○ 00.000	Neutral	<b>48,00</b>
----------	---------	--------------

## 12665



- Ghiera di fissaggio per cartuccia.
- Fixing plug for cartridge.
- Bouchon de fixation.
- Befestigungsring für Einhebel-Mischer.
- Anilla de fijación para cartucho.

● 21.018	Chrome	<b>52,00</b>
● 31.028	Brushed Nickel	<b>54,00</b>
● 47.083	Groove bronze	<b>61,00</b>



# **KITCHEN EXPERIENCE**

**STAINLESS STEEL**

# STEEL LINE

STAINLESS STEEL 316

new

FULL STYLE



**50.050** STAINLESS STEEL



**01.093** NERO OPACO / MATT BLACK



STEEL LINE



### 74100X

- Miscelatore monocomando per lavello con bocca girevole.
- *Single-lever sink mixer with swivel spout.*
- Mitigeur monocommande pour évier avec bec pivotant.
- *Einhebel-Spültischmischer mit schwenkbarem Auslauf.*
- Mezclador monomando para fregadero con caño giratorio.



26825



13327



31456

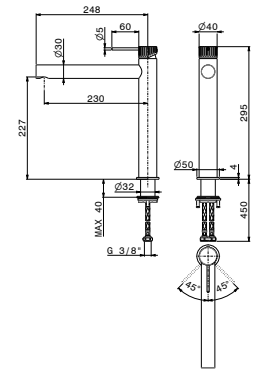

- 50.050 Stainless Steel
- 01.093 Matt black

380,00  
399,00



### 74120X

- Miscelatore monocomando per lavello con bocca quadra girevole.
- *Single-lever sink mixer with squared swivel spout.*
- Mitigeur monocommande pour évier avec bec carré pivotant.
- *Einhebel-Spültischmischer mit quadratischem Schwenkauslauf.*
- Mezclador monomando para fregadero con caño cuadrado giratorio.



26901



31458

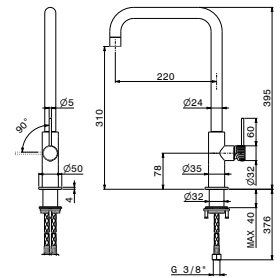

- 50.050 Stainless Steel
- 01.093 Matt black

344,00  
385,00



### 74125X

- Miscelatore monocomando per lavello con bocca L girevole e doccia estraibile.
- *Single-lever sink mixer with L swivel spout and pull-out hand shower.*
- Mitigeur monocommande pour évier avec bec L pivotant et douche extractible.
- *Einhebel-Spültischmischer mit schwenkbarem L-Auslauf und ausziehbarer Handbrause.*
- Mezclador monomando para fregadero con caño con forma de L giratorio y ducha extraíble.



26825



13327



33373X



31458

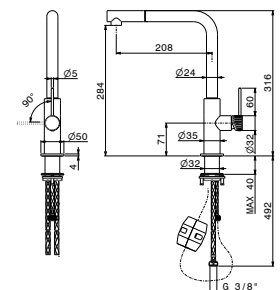

- 50.050 Stainless Steel
- 01.093 Matt black

421,00  
439,00

### 74140X

- Miscelatore monocomando per lavello con bocca L girevole e comando frontale.
- *Single-lever sink mixer with L swivel spout and front lever.*
- Mitigeur monocommande pour évier avec bec L pivotant et commande frontale .
- *Einhebel-Spültischmischer mit schwenkbarem L-Auslauf und Front Bedienung.*
- Mezclador monomando para fregadero con caño con forma de L giratorio y mando frontal.

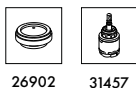

26902 31457

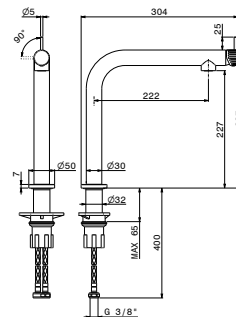

- 50.050 Stainless Steel **342,00**
- 01.093 Matt black **376,00**

### 74130X new

- Gruppo miscelatore monocomando per lavello con bocca piatta abbattibile.
- *Single-lever sink group with flat pull-down spout.*
- Mitigeur monocommande pour évier avec bec plat rabattable .
- *Einhebel-Spültischmischer mit flachem, abklappbarem Auslauf.*
- Grupo mezclador monomando para fregadero con caño plano retráctil.

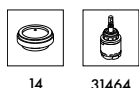

14 31464

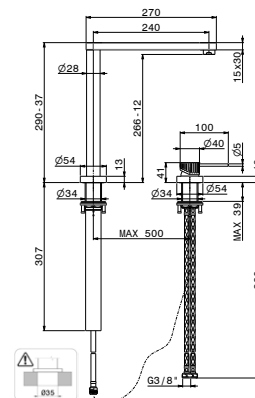

- 50.050 Stainless Steel **571,00**
- 01.093 Matt black **604,00**

### 74135X new

- Gruppo miscelatore monocomando per lavello con bocca abbattibile e doccia estraibile.
- *Single-lever sink group with pull-down spout and pull-out hand shower.*
- Mitigeur monocommande évier avec bec rabattable et douchette extractible .
- *Einhebel- Spültischmischer mit abklappbarem Auslauf und herausziehbarer Handbrause.*
- Grupo mezclador monomando para fregadero con caño retráctil y ducha extraíble.

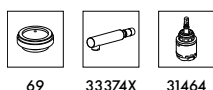

69 33374X 31464

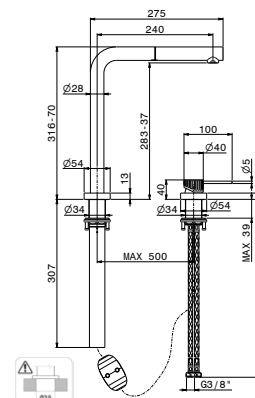

- 50.050 Stainless Steel **721,00**
- 01.093 Matt black **752,00**



## 74118X

- Dispenser in acciaio per sapone liquido.
- *Steel soap dispenser.*
- Distributeur de savon en acier .
- *Flüssigseifenspender aus Stahl.*
- Dispensador de acero para jabón líquido.

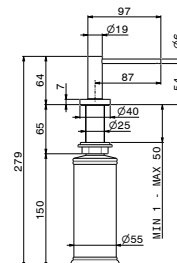

- **50.050** Stainless Steel
- **01.093** Matt black

**120,00**  
**131,00**

Al momento dell'ordine del ricambio si prega di indicare il prodotto su cui dovrà essere installato al fine di determinare il modello corretto da fornire, comprensivo di eventuale tampografia.  
 When ordering the spare part, please specify the product it will be installed on, in order to determine the correct model to provide, including any required pad printing.  
 Lors de la commande de la pièce détachée, veuillez indiquer le produit sur lequel sera installée afin de déterminer le modèle correct à fournir, y compris toute tampographie éventuelle.  
 Bitte geben Sie bei der Bestellung des Ersatzteils das Produkt an, auf dem es installiert werden soll, um das richtige Modell einschließlich etwaiger Tampondrucke zu bestimmen.  
 Al realizar el pedido del repuesto, indique el producto en el que se instalará para determinar el modelo correcto a suministrar, incluyendo cualquier tampografía necesaria.

### 33371X



- Maniglia per art.:
- Handle for art.:
- Manette pour art.:
- Griff für art.:
- Manija para art.:

**74120X, 74125X.**

● **50.050** Stainless Steel **64,00**  
 ● **01.093** Matt black **67,00**

### 33370X



- Maniglia per art.:
- Handle for art.:
- Manette pour art.:
- Griff für art.:
- Manija para art.:

**74140X.**

● **50.050** Stainless Steel **72,00**  
 ● **01.093** Matt black **75,00**

### 33312X



- Cappuccio coprighiera per art.:
- Cover ring nut cap for art.:
- Cache écrou couvre-joint pour art.:
- Ringverkleidung für art.:
- Embellecedor de anilla para art.:

**74120X, 74125X.**

● **50.050** Stainless Steel **31,00**  
 ● **01.093** Matt black **33,00**

### 33310X

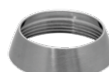

- Cappuccio coprighiera per art.:
- Cover ring nut cap for art.:
- Cache écrou couvre-joint pour art.:
- Ringverkleidung für art.:
- Embellecedor de anilla para art.:

**74140X.**

● **50.050** Stainless Steel **31,00**  
 ● **01.093** Matt black **33,00**

### 33311



- Ghiera di fissaggio per art.:
- Fixing plug for art.:
- Écrou de fixation pour art.:
- Befestigungsring für art.:
- Anilla de fijación para art.:

**74120X, 74125X.**

○ **00.000** Neutral **29,00**

### 33309



- Ghiera di fissaggio per art.:
- Fixing plug for art.:
- Écrou de fixation pour art.:
- Befestigungsring für art.:
- Anilla de fijación para art.:

**74140X.**

○ **00.000** Neutral **29,00**

### 31458



- Cartuccia a dischi ceramici per art.:
- Cartridge with ceramic discs for art.:
- Cartouche à disque céramique pour art.:
- Keramikscheibenkartusche für Art.-Nr.:
- Cartucho de discos cerámicos para art.:

**74120X, 74125X.**

○ **00.000** Neutral **43,00**

### 31457



- Cartuccia a dischi ceramici per art.:
- Cartridge with ceramic discs for art.:
- Cartouche à disque céramique pour art.:
- Keramikscheibenkartusche für Art.-Nr.:
- Cartucho de discos cerámicos para art.:

**74140X.**

○ **00.000** Neutral **43,00**

### 33373X



- Doccetta per art.:
- Hand shower for art.:
- Douchette pour art.:
- Handbrause für Art.-Nr.:
- Ducha para art.:

**74125X.**

● **50.050** Stainless Steel **65,00**  
 ● **01.093** Matt black **73,00**

Al momento dell'ordine del ricambio si prega di indicare il prodotto su cui dovrà essere installato al fine di determinare il modello corretto da fornire, comprensivo di eventuale tampografia.  
 When ordering the spare part, please specify the product it will be installed on, in order to determine the correct model to provide, including any required pad printing.  
 Lors de la commande de la pièce détachée, veuillez indiquer le produit sur lequel sera installée afin de déterminer le modèle correct à fournir, y compris toute tampographie éventuelle.  
 Bitte geben Sie bei der Bestellung des Ersatzteils das Produkt an, auf dem es installiert werden soll, um das richtige Modell einschließlich etwaiger Tampondrucke zu bestimmen.  
 Al realizar el pedido del repuesto, indique el producto en el que se instalará para determinar el modelo correcto a suministrar, incluyendo cualquier tampografía necesaria.

### 33372X

- Maniglia per art.:
- Handle for art.:
- Manette pour art.:
- Griff für art.:
- Manija para art.:

74100X - 74130X - 74135.



● 50.050 Stainless Steel 72,00  
 ● 01.093 Matt black 75,00

### 33374X

- Doccetta per art.:
- Hand shower for art.:
- Douchette pour art.:
- Handbrause für Art.-Nr.:
- Ducha para art.:

74135X.



● 50.050 Stainless Steel 89,00  
 ● 01.093 Matt black 103,00

### 33308X

- Cappuccio coprihiera per art.:
- Cover ring nut cap for art.:
- Cache écrou couvre-joint pour art.:
- Ringverkleidung für art.:
- Embellecedor de anilla para art.:

74100X.



● 50.050 Stainless Steel 31,00  
 ● 01.093 Matt black 33,00

### 33317X

- Cappuccio coprihiera per art.:
- Cover ring nut cap for art.:
- Cache écrou couvre-joint pour art.:
- Ringverkleidung für art.:
- Embellecedor de anilla para art.:

74130X - 74135X.



● 50.050 Stainless Steel 31,00  
 ● 01.093 Matt black 33,00

### 33307

- Ghiera di fissaggio per art.:
- Fixing plug for art.:
- Écrou de fixation pour art.:
- Befestigungsring für art.:
- Anilla de fijación para art.:

74100X.



○ 00.000 Neutral 29,00

### 33318

- Ghiera di fissaggio per art.:
- Fixing plug for art.:
- Écrou de fixation pour art.:
- Befestigungsring für art.:
- Anilla de fijación para art.:

74130X - 74135X.



○ 00.000 Neutral 29,00

### 31464

- Cartuccia a dischi ceramici per art.:
- Cartridge with ceramic discs for art.:
- Cartouche à disque céramique pour art.:
- Keramikscheibenkartusche für Art.-Nr.:
- Cartucho de discos cerámicos para art.:

74130X - 74135X.



○ 00.000 Neutral 43,00

### 31456

- Cartuccia a dischi ceramici per art.:
- Cartridge with ceramic discs for art.:
- Cartouche à disque céramique pour art.:
- Keramikscheibenkartusche für Art.-Nr.:
- Cartucho de discos cerámicos para art.:

74100X.



○ 00.000 Neutral 43,00



# REAL STEEL

FULL STYLE



**50.050** STAINLESS STEEL



REAL STEEL

**63420X**

- Miscelatore monocomando per lavello con bocca quadra girevole.
- *Single-lever sink mixer with squared swivel spout.*
- Mitigeur monocommande évier avec bec carré pivotant .
- Einhebel-Spültischmischer mit quadratischem Schwenkauslauf.
- Mezclador monomando para fregadero con caño cuadrado giratorio.



26829X



14720

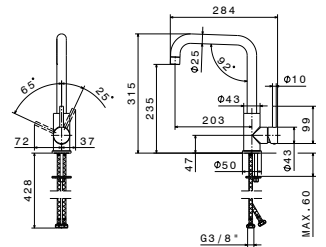

● 50.050 Stainless Steel

**306,00****63421X**

- Miscelatore monocomando per lavello con bocca tonda girevole.
- *Single-lever sink mixer with round swivel spout.*
- Mitigeur monocommande évier avec bec rond pivotant .
- Spültisch-Einhandbatterie mit rundem Schwenkauslauf.
- Mezclador monomando para fregadero con caño redondo giratorio.



26829X



14720

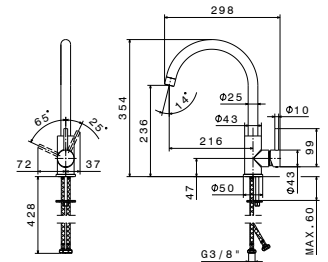

● 50.050 Stainless Steel

**306,00****63422X**

- Miscelatore monocomando per lavello con bocca L girevole.
- *Single-lever sink mixer with L swivel spout.*
- Mitigeur monocommande évier avec bec L pivotant .
- Einhebel-Spültischmischer mit drehbarem L-Auslauf.
- Mezclador monomando para fregadero con caño con forma de L giratorio.



26813



14720

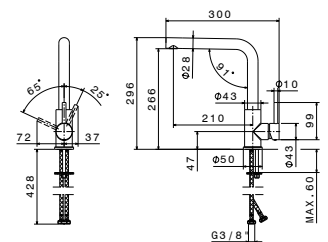

● 50.050 Stainless Steel

**330,00**

## 63425X

- Miscelatore monocomando per lavello con bocca L girevole e doccia estraibile.
- *Single-lever sink mixer with L swivel spout and pull-out hand shower.*
- Mitigeur monocommande évier avec bec L pivotant et douchette extractible .
- *Einhebel-Spültischmischer mit schwenkbarem L-Auslauf und ausziehbarer Handbrause.*
- Mezclador monomando para fregadero con caño con forma de L giratorio y ducha extraíble.

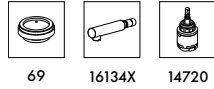

69

16134X

14720

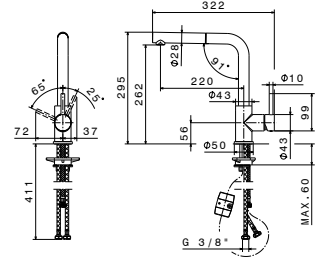

● 50.050 Stainless Steel

495,00

## 63435X

- Miscelatore monocomando per lavello con bocca tonda girevole e doccia estraibile doppio getto.
- *Single-lever sink mixer with round swivel spout and double-jet pull-out hand shower.*
- Mitigeur monocommande évier avec bec rond pivotant et douchette extractible double jet .
- *Einhebel- Küchenmischer mit rundem Schwenkauslauf, Ausziehbrause, 2jet.*
- Mezclador monomando para fregadero con caño redondo giratorio y ducha extraíble de doble chorro.

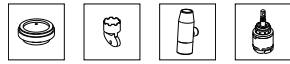

26830

13361

24591X

14720

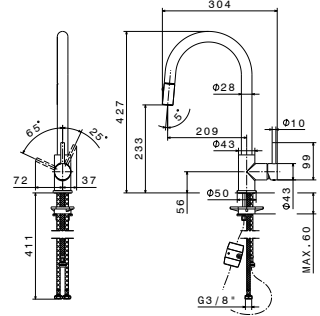

● 50.050 Stainless Steel

535,00

## 2418X

- Dispenser per sapone liquido.
- *Soap dispenser.*
- Distributeur de savon .
- *Flüssigseifenspender.*
- Dispensador de jabón líquido.

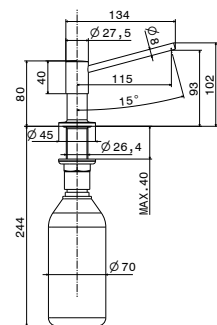

● 50.050 Stainless Steel

322,00

Al momento dell'ordine del ricambio si prega di indicare il prodotto su cui dovrà essere installato al fine di determinare il modello corretto da fornire, comprensivo di eventuale tampografia.  
 When ordering the spare part, please specify the product it will be installed on, in order to determine the correct model to provide, including any required pad printing.

Lors de la commande de la pièce détachée, veuillez indiquer le produit sur lequel sera installée afin de déterminer le modèle correct à fournir, y compris toute tampographie éventuelle.

Bitte geben Sie bei der Bestellung des Ersatzteils das Produkt an, auf dem es installiert werden soll, um das richtige Modell einschließlich etwaiger Tampondrucke zu bestimmen.

Al realizar el pedido del repuesto, indique el producto en el que se instalará para determinar el modelo correcto a suministrar, incluyendo cualquier tampografía necesaria.

## 24581X



- Maniglia per collezione REAL STEEL.
- Handle for REAL STEEL collection.
- Manette complète pour collection REAL STEEL.
- Griff für die Küchenkollektion REAL STEEL.
- Manija para colección REAL STEEL.

● 50.050 Stainless Steel 60,00

## 14720



- Cartuccia a dischi ceramici.
- Cartridge with ceramic discs.
- Cartouche à disque céramique.
- Keramikscheibenkartusche.
- Cartucho de discos cerámicos.

○ 00.000 Neutral 37,00

## 16134X



- Doccetta per art.:
- Hand shower for art.:
- Douchette pour art.:
- Handbrause für Art.-Nr.:
- Ducha para art.:

63425X.

● 50.050 Stainless Steel 135,00

## 24591X



- Doccetta doppio getto per art.:
- Double-jet hand shower for art.:
- Douchette double jet pour art.:
- Doppelstrahl-Handbrause für Art.-Nr.:
- Ducha de doble chorro para art.:

63435X.

● 50.050 Stainless Steel 162,00

## 24583



- Ghiera di fissaggio cartuccia per collezione REAL STEEL.
- Fixing ring nut for REAL STEEL collection cartridge.
- Écrou de fixation pour cartouche collection REAL STEEL.
- Befestigungsring für Kartusche der Küchenkollektion REAL STEEL.
- Anilla de fijación de cartucho para colección REAL STEEL.

○ 00.000 Neutral 37,00

## 24582X



- Cappuccio coprighiera per collezione REAL STEEL.
- Cover ring nut cap for REAL STEEL collection.
- Cache écrou couvre-joint en ABS pour collection REAL STEEL.
- Ringkappe aus ABS für die Küchenkollektion REAL STEEL.
- Embellecedor de anilla para colección REAL STEEL.

● 50.050 Stainless Steel 37,00



# X-TREND INOX

STAINLESS STEEL 316

FULL STYLE



**50.050** STAINLESS STEEL

---



## 2400X

- Miscelatore monocomando per lavello con bocca girevole e terminale orientabile.
- *Single-lever sink mixer with swivel spout and adjustable outlet.*
- Mitigeur monocommande évier avec bec pivotant et orientable .
- Einhebel-Spültischmischer mit schwenkbarem Auslauf und verstellbarem Anschluss.
- Mezclador monomando para fregadero con caño giratorio y terminal orientable.



26888



14720



● 50.050 Stainless Steel

580,00

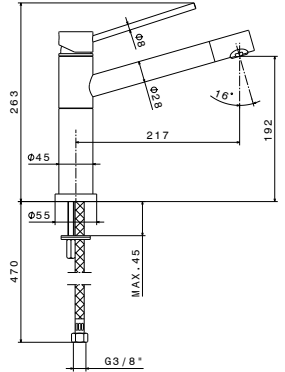

## 2415X

- Miscelatore monocomando per lavello con bocca girevole e doccetta estraibile.
- *Single-lever sink mixer with swivel spout and pull-out hand shower.*
- Mitigeur monocommande évier avec bec pivotant et douchette extractible .
- Einhebel- Küchenmischer mit Schwenkauslauf, Ausziehbrause.
- Mezclador monomando para fregadero con caño giratorio y ducha extraíble.



69



16134X



14720



● 50.050 Stainless Steel

768,00

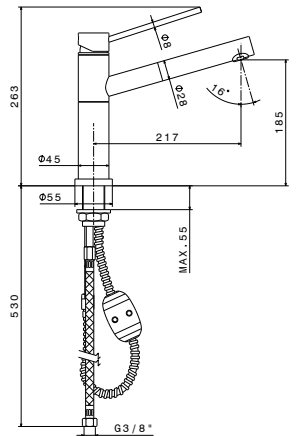

## 2418X

- Dispenser per sapone liquido.
- *Soap dispenser.*
- Distributeur de savon .
- Flüssigseifenspender.
- Dispensador de jabón líquido.

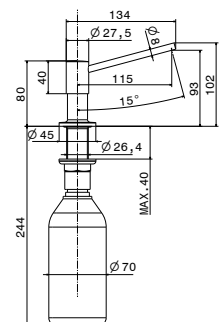

● 50.050 Stainless Steel

322,00

Al momento dell'ordine del ricambio si prega di indicare il prodotto su cui dovrà essere installato al fine di determinare il modello corretto da fornire, comprensivo di eventuale tampografia.  
 When ordering the spare part, please specify the product it will be installed on, in order to determine the correct model to provide, including any required pad printing.

Lors de la commande de la pièce détachée, veuillez indiquer le produit sur lequel sera installée afin de déterminer le modèle correct à fournir, y compris toute tampographie éventuelle.

Bitte geben Sie bei der Bestellung des Ersatzteils das Produkt an, auf dem es installiert werden soll, um das richtige Modell einschließlich etwaiger Tampondrucke zu bestimmen.

Al realizar el pedido del repuesto, indique el producto en el que se instalará para determinar el modelo correcto a suministrar, incluyendo cualquier tampografía necesaria.

## 16124

- Maniglia per collezione X-TREND INOX.
- Handle for X-TREND INOX collection.
- Manette complète pour collection X-TREND INOX.
- Griff für die Küchenkollektion X-TREND INOX.
- Manija para colección X-TREND INOX.



● 50.050 Stainless Steel 102,00

## 16134X

- Doccetta per art.:
- Hand shower for art.:
- Douchette pour art.:
- Handbrause für Art.-Nr.:
- Ducha para art.:



2415X.

● 50.050 Stainless Steel 135,00



## 16006

- Ghiera di fissaggio cartuccia per collezione X-TREND INOX.
- Fixing ring nut for X-TREND INOX cartridge.
- Écrou de fixation pour cartouche collection X-TREND INOX.
- Befestigungsring für Kartusche der Küchenkollektion X-TREND INOX.
- Anilla de fijación de cartucho para colección X-TREND INOX.



● 50.050 Stainless Steel 55,00

## 14720

- Cartuccia a dischi ceramici.
- Cartridge with ceramic discs.
- Cartouche à disque céramique.
- Keramikscheibenkartusche.
- Cartucho de discos cerámicos.



○ 00.000 Neutral 37,00

# **ACCESSORI TECNICI**

## ***TECHNICAL ACCESSORIES***

**ACCESSOIRES TECHNIQUES / TECHNISCHE ACCESSOIRES**  
**ACCESORIOS TÉCNICOS**

## 11061



- Tubetti di alimentazione M10x1 con O-Ring per monocomando. L=350 mm. Confezione da 2 pz.
- Connection pipes M10x1 with O-Ring for single-lever mixers. L=350 mm. Two-pack.
- Tuyaux de raccordement M10x1 avec joint torique pour mélangeurs à levier unique . L=350 mm . Emballage de 2 pièces .
- Versorgungsrohre M10x1 mit O-Ring zur Einzelbedienung. L=350 mm. Verpackung mit 2 Stk.
- Tubos de alimentación M10x1 con junta tórica para monomando. L=350 mm Envase de 2 uds.

● 21.018	Chrome	<b>44,00</b>
● 31.028	Brushed Nickel	<b>60,00</b>
● 47.083	Groove bronze	<b>66,00</b>

## 10140



- Tubetti di alimentazione M8x1 con O-Ring per monocomando. L=350 mm. Confezione da 2 pz.
- Connection pipes M8x1 with O-Ring for single-lever mixers. L=350 mm. Two-pack.
- Tuyaux de raccordement M8x1 avec joint torique pour mélangeurs à levier unique . L=350 mm . Emballage de 2 pièces .
- Versorgungsrohre M8x1 mit O-Ring zur Einzelbedienung. L=350 mm. Verpackung mit 2 Stk.
- Tubos de alimentación M8x1 con junta tórica para monomando. L=350 mm Envase de 2 uds.

● 21.018	Chrome	<b>37,00</b>
● 31.028	Brushed Nickel	<b>60,00</b>
● 47.083	Groove bronze	<b>66,00</b>

## 18057



- Flessibili di alimentazione M8x1-F3/8" per monocomando. L=460 mm. Confezione da 2 pz.
- Connection hoses M8x1-F3/8" for single-lever mixers. L=460 mm. Two-pack.
- Flexibles de raccordement M8x1-F3/8" pour mitigeurs monocommande . L=460 mm . Emballage de 2 pièces .
- Versorgungsschläuche M8x1-F3/8" für Einhebel. L=460 mm. Verpackung mit 2 Stk.
- Flexibles de alimentación M8x1-F3/8" para monomando. L=460 mm Envase de 2 uds.

○ 00.000	Neutral	<b>46,00</b>
----------	---------	--------------

## 125



- Rubinetto sottolavello a sfera con filtro da 1/2". Confezione da 2 pz.
- Ball valve with 1/2" filter. Two-pack.
- Tête à bille avec filtre, union 1/2" . Emballage de 2 pièces .
- Untertisch-Kugelhahn mit 1/2-Zoll-Filter. Verpackung mit 2 Stk.
- Llave de paso de bola con filtro de 1/2". Envase de 2 uds.

● 21.018	Chrome	<b>119,00</b>
● 01.014	Matt white	<b>181,00</b>
● 01.093	Matt black	<b>181,00</b>
● 31.028	Brushed Nickel	<b>239,00</b>
● 47.083	Groove bronze	<b>248,00</b>
● 59.064	PVD Br. Gun Metal	<b>312,00</b>
● 59.066	PVD Br. Stainless Seel	<b>312,00</b>
● 59.067	PVD Br. Copper Bronze	<b>312,00</b>
● 59.098	PVD Br. Pale Gold	<b>312,00</b>
● M0.077	Carbon Satin	<b>267,00</b>



SCHEMI DI PORTATA  
*FLOW RATE CHARTS*  
DÉBIT D'EAU  
*DIAGRAMM DIE WASSERFLUSS*  
DIAGRAMAS DE FLUJO

## KONBU

art.

		pressione/pressure/pression/druck/presión (bar)			
		1	2	3	4
<b>72521</b>		portata/flow rate/débit/Wasserfluss/caudal (l/min)			
		3,9	5,2	5,4	5,4
		pressione/pressure/pression/druck/presión (bar)			
		1	2	3	4
<b>72525</b>		portata/flow rate/débit/Wasserfluss/caudal (l/min)			
		3,5	5	5,6	5
		pressione/pressure/pression/druck/presión (bar)			
		1	2	3	4
<b>72520</b>		portata/flow rate/débit/Wasserfluss/caudal (l/min)			
		3,9	5,2	5,4	5,4
		pressione/pressure/pression/druck/presión (bar)			
		1	2	3	4
<b>72522</b>		portata/flow rate/débit/Wasserfluss/caudal (l/min)			
		4	5,3	5,4	5,4
		pressione/pressure/pression/druck/presión (bar)			
		1	2	3	4
<b>72535</b>		portata/flow rate/débit/Wasserfluss/caudal (l/min)			
		3,3	4,6	4,8	4,7
		pressione/pressure/pression/druck/presión (bar)			
		1	2	3	4
<b>72545</b>		portata/flow rate/débit/Wasserfluss/caudal (l/min)			
		3,7	5	5,3	5,3

## N21

art.

		pressione/pressure/pression/druck/presión (bar)			
		1	2	3	4
<b>71730</b>		portata/flow rate/débit/Wasserfluss/caudal (l/min)			
		2,1	3	3,7	4,3
		pressione/pressure/pression/druck/presión (bar)			
		1	2	3	4
<b>71730</b>		portata/flow rate/débit/Wasserfluss/caudal (l/min)			
		2,6	4,2	5,4	6,4
		pressione/pressure/pression/druck/presión (bar)			
		1	2	3	4
<b>71720</b>		portata/flow rate/débit/Wasserfluss/caudal (l/min)			
		3,7	5,1	5,7	5,4
		pressione/pressure/pression/druck/presión (bar)			
		1	2	3	4
<b>71721</b>		portata/flow rate/débit/Wasserfluss/caudal (l/min)			
		2,1	3	3,7	4,3
		pressione/pressure/pression/druck/presión (bar)			
		1	2	3	4
<b>71725</b>		portata/flow rate/débit/Wasserfluss/caudal (l/min)			
		3,6	4,9	5,2	5,1
		pressione/pressure/pression/druck/presión (bar)			
		1	2	3	4
<b>71731</b>		portata/flow rate/débit/Wasserfluss/caudal (l/min)			
		2,1	3	3,7	4,3
		pressione/pressure/pression/druck/presión (bar)			
		1	2	3	4
<b>71731</b>		portata/flow rate/débit/Wasserfluss/caudal (l/min)			
		2,6	4,2	5,4	6,4

## ALKIMIA

art.

		pressione/pressure/pression/druck/presión (bar)			
		1	2	3	4
<b>73300</b>		portata/flow rate/débit/Wasserfluss/caudal (l/min)			
		3,2	4,4	4,5	4,5
		pressione/pressure/pression/druck/presión (bar)			
		1	2	3	4
<b>73301</b>		portata/flow rate/débit/Wasserfluss/caudal (l/min)			
		3,2	4,4	4,5	4,5
		pressione/pressure/pression/druck/presión (bar)			
		1	2	3	4
<b>73302</b>		portata/flow rate/débit/Wasserfluss/caudal (l/min)			
		3,2	4,4	4,5	4,5
		pressione/pressure/pression/druck/presión (bar)			
		1	2	3	4
<b>73304</b>		portata/flow rate/débit/Wasserfluss/caudal (l/min)			
		3,2	4,4	4,5	4,5
		pressione/pressure/pression/druck/presión (bar)			
		1	2	3	4
<b>73306</b>		portata/flow rate/débit/Wasserfluss/caudal (l/min)			
		3,2	4,4	4,5	4,5



## MAKI

art.

		pressione/pressure/pression/druck/presión (bar)			
		1	2	3	4
<b>71820</b>		portata/flow rate/débit/Wasserfluss/caudal (l/min)			
		2,2	3,2	3,9	4,6
		pressione/pressure/pression/druck/presión (bar)			
		1	2	3	4
<b>71830</b>		portata/flow rate/débit/Wasserfluss/caudal (l/min)			
		2,2	3,2	3,9	4,6
		pressione/pressure/pression/druck/presión (bar)			
		1	2	3	4
<b>71821</b>		portata/flow rate/débit/Wasserfluss/caudal (l/min)			
		2,2	3,2	3,9	4,6
		pressione/pressure/pression/druck/presión (bar)			
		1	2	3	4
<b>71822</b>		portata/flow rate/débit/Wasserfluss/caudal (l/min)			
		4,2	5,5	5,6	5,5
		pressione/pressure/pression/druck/presión (bar)			
		1	2	3	4
<b>71825</b>		portata/flow rate/débit/Wasserfluss/caudal (l/min)			
		3,2	4,6	5,2	5,1
		pressione/pressure/pression/druck/presión (bar)			
		1	2	3	4
<b>71823</b>		portata/flow rate/débit/Wasserfluss/caudal (l/min)			
		4	4,8	4,9	5
		pressione/pressure/pression/druck/presión (bar)			
		1	2	3	4
<b>71845</b>		portata/flow rate/débit/Wasserfluss/caudal (l/min)			
		4	5,3	5	5,1
		pressione/pressure/pression/druck/presión (bar)			
		1	2	3	4
<b>71850</b>		portata/flow rate/débit/Wasserfluss/caudal (l/min)			
		3,7	5	5,3	5,3



## O'RAMA

art.

		pressione/pressure/presion/druck/presión (bar)			
		1	2	3	4
<b>68735</b>		portata/flow rate/débit/Wasserfluss/caudal (l/min)			
		2,8	4	4,7	5,4
<b>68735</b>		pressione/pressure/presion/druck/presión (bar)			
		1	2	3	4
<b>68735</b>		portata/flow rate/débit/Wasserfluss/caudal (l/min)			
		2,8	3,9	4,6	5,3









## LIBERA

art.

		pressione/pressure/presion/druck/presión (bar)			
		1	2	3	4
<b>63915</b>		portata/flow rate/débit/Wasserfluss/caudal (l/min)			
		4	5	4,7	4,9
<b>63915</b>	GETTO N. 2 / JET N.2	pressione/pressure/presion/druck/presión (bar)			
		1	2	3	4
<b>63915</b>	GETTO N. 2 / JET N.2	portata/flow rate/débit/Wasserfluss/caudal (l/min)			
		3,6	4,7	4,8	5
<b>63930</b>		pressione/pressure/presion/druck/presión (bar)			
		1	2	3	4
<b>63930</b>		portata/flow rate/débit/Wasserfluss/caudal (l/min)			
		3,9	4,9	4,7	5,1
<b>63930</b>	GETTO N. 2 / JET N.2	pressione/pressure/presion/druck/presión (bar)			
		1	2	3	4
<b>63930</b>	GETTO N. 2 / JET N.2	portata/flow rate/débit/Wasserfluss/caudal (l/min)			
		3,5	4,6	4,6	4,9





## ERGO

art.

		pressione/pressure/presion/druck/presión (bar)			
		1	2	3	4
<b>65910</b>		portata/flow rate/débit/Wasserfluss/caudal (l/min)			
		4,3	4,7	4,8	4,7
<b>65915</b>		pressione/pressure/presion/druck/presión (bar)			
		1	2	3	4
<b>65915</b>		portata/flow rate/débit/Wasserfluss/caudal (l/min)			
		3,5	5	4,9	4,6
<b>65920</b>		pressione/pressure/presion/druck/presión (bar)			
		1	2	3	4
<b>65920</b>		portata/flow rate/débit/Wasserfluss/caudal (l/min)			
		2,3	3,3	4	4,7
<b>65921</b>		pressione/pressure/presion/druck/presión (bar)			
		1	2	3	4
<b>65921</b>		portata/flow rate/débit/Wasserfluss/caudal (l/min)			
		2,3	3,3	4	4,7
<b>65925</b>		pressione/pressure/presion/druck/presión (bar)			
		1	2	3	4
<b>65925</b>		portata/flow rate/débit/Wasserfluss/caudal (l/min)			
		4,1	5,9	7,3	7,7
<b>65925</b>	GETTO N. 2 / JET N.2	pressione/pressure/presion/druck/presión (bar)			
		1	2	3	4
<b>65925</b>	GETTO N. 2 / JET N.2	portata/flow rate/débit/Wasserfluss/caudal (l/min)			
		3,8	5,3	6,6	7,7









## YCON

art.

		pressione/pressure/presion/druck/presión (bar)			
		1	2	3	4
<b>64200</b>		portata/flow rate/débit/Wasserfluss/caudal (l/min)			
		3,9	5	4,5	4,5
<b>64215</b>		pressione/pressure/presion/druck/presión (bar)			
		1	2	3	4
<b>64215</b>		portata/flow rate/débit/Wasserfluss/caudal (l/min)			
		3,2	4,6	4,7	4,5
<b>64213</b>		pressione/pressure/presion/druck/presión (bar)			
		1	2	3	4
<b>64213</b>		portata/flow rate/débit/Wasserfluss/caudal (l/min)			
		3,8	4,8	4,7	4,9

## MOONY

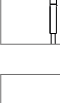
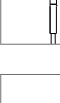
art.

		pressione/pressure/presion/druck/presión (bar)			
		1	2	3	4
<b>3100</b>		portata/flow rate/débit/Wasserfluss/caudal (l/min)			
		4,3	4,9	4,5	4,5
<b>3101</b>	MISCELATORE / MIXER	pressione/pressure/presion/druck/presión (bar)			
		1	2	3	4
<b>3101</b>	MISCELATORE / MIXER	portata/flow rate/débit/Wasserfluss/caudal (l/min)			
		2,6	3,7	4,6	5,2
<b>3103</b>	MISCELATORE / MIXER	pressione/pressure/presion/druck/presión (bar)			
		1	2	3	4
<b>3103</b>	MISCELATORE / MIXER	portata/flow rate/débit/Wasserfluss/caudal (l/min)			
		2,6	3,7	4,6	5,2
<b>3110</b>		pressione/pressure/presion/druck/presión (bar)			
		1	2	3	4
<b>3110</b>		portata/flow rate/débit/Wasserfluss/caudal (l/min)			
		4,1	5,1	4,6	4,5
<b>3125</b>		pressione/pressure/presion/druck/presión (bar)			
		1	2	3	4
<b>3125</b>		portata/flow rate/débit/Wasserfluss/caudal (l/min)			
		3,8	4,9	4,5	4,4
<b>3140</b>		pressione/pressure/presion/druck/presión (bar)			
		1	2	3	4
<b>3140</b>		portata/flow rate/débit/Wasserfluss/caudal (l/min)			
		4,4	4,7	5,1	5,2
<b>3155</b>		pressione/pressure/presion/druck/presión (bar)			
		1	2	3	4
<b>3155</b>		portata/flow rate/débit/Wasserfluss/caudal (l/min)			
		3,7	4,9	4,9	5,1
<b>3155</b>		pressione/pressure/presion/druck/presión (bar)			
		1	2	3	4
<b>3155</b>		portata/flow rate/débit/Wasserfluss/caudal (l/min)			
		3,9	4,9	4,7	5,1

## X-TREND

art.

		pressione/pressure/presion/druck/presión (bar)			
		1	2	3	4
<b>2400</b>	portata/flow rate/débit/Wasserfluss/caudal (l/min)				
		4,2	4,7	4,3	4,5
		pressione/pressure/presion/druck/presión (bar)			
		1	2	3	4
<b>2415</b>	portata/flow rate/débit/Wasserfluss/caudal (l/min)				
		4,2	4,2	4,8	5
		pressione/pressure/presion/druck/presión (bar)			
		1	2	3	4
<b>2439</b>	portata/flow rate/débit/Wasserfluss/caudal (l/min)				
		3,7	4,8	4,3	4,4
		pressione/pressure/presion/druck/presión (bar)			
		1	2	3	4
<b>2260</b>	portata/flow rate/débit/Wasserfluss/caudal (l/min)				
		4,2	5,5	5,4	5,3

## XT

art.

		pressione/pressure/presion/druck/presión (bar)			
		1	2	3	4
<b>4319</b>	portata/flow rate/débit/Wasserfluss/caudal (l/min)				
		4,2	5,5	5,5	5,4
		pressione/pressure/presion/druck/presión (bar)			
		1	2	3	4
<b>4320</b>	portata/flow rate/débit/Wasserfluss/caudal (l/min)				
		2,4	3,4	4,2	4,9
		pressione/pressure/presion/druck/presión (bar)			
		1	2	3	4
<b>4325</b>	portata/flow rate/débit/Wasserfluss/caudal (l/min)				
		2,4	3,4	4,2	4,9
		pressione/pressure/presion/druck/presión (bar)			
		1	2	3	4
<b>4340</b>	portata/flow rate/débit/Wasserfluss/caudal (l/min)				
		3,5	4,8	4,9	4,8
		pressione/pressure/presion/druck/presión (bar)			
		1	2	3	4
<b>4345</b>	portata/flow rate/débit/Wasserfluss/caudal (l/min)				
		3,4	4,6	5	4,8
		pressione/pressure/presion/druck/presión (bar)			
		1	2	3	4
<b>4370</b>	portata/flow rate/débit/Wasserfluss/caudal (l/min)				
		2,4	3,4	4,2	4,9
		pressione/pressure/presion/druck/presión (bar)			
		1	2	3	4
<b>4371</b>	portata/flow rate/débit/Wasserfluss/caudal (l/min)				
		2,4	3,4	4,2	4,9

## MARVEL

art.

		pressione/pressure/presion/druck/presión (bar)			
		1	2	3	4
<b>8550</b>	portata/flow rate/débit/Wasserfluss/caudal (l/min)				
		7,37	10,59	13,03	15,1
		pressione/pressure/presion/druck/presión (bar)			
		1	2	3	4
<b>8650</b>	portata/flow rate/débit/Wasserfluss/caudal (l/min)				
		8,04	11,55	14,22	16,54

## REAL

art.

		pressione/pressure/presion/druck/presión (bar)			
		1	2	3	4
<b>63420</b>	portata/flow rate/débit/Wasserfluss/caudal (l/min)				
		8,85	12,69	15,64	18,17
		pressione/pressure/presion/druck/presión (bar)			
		1	2	3	4
<b>63421</b>	portata/flow rate/débit/Wasserfluss/caudal (l/min)				
		8,89	12,77	15,65	18,15
		pressione/pressure/presion/druck/presión (bar)			
		1	2	3	4
<b>63425</b>	portata/flow rate/débit/Wasserfluss/caudal (l/min)				
		5,59	8,28	10,33	12,09

## STEEL LINE

art.

		pressione/pressure/presion/druck/presión (bar)			
		1	2	3	4
<b>74100X</b>	portata/flow rate/débit/Wasserfluss/caudal (l/min)				
		4,1	4,6	4,8	5
		pressione/pressure/presion/druck/presión (bar)			
		1	2	3	4
<b>74120X</b>	portata/flow rate/débit/Wasserfluss/caudal (l/min)				
		3,5	4,9	5,2	4,8
		pressione/pressure/presion/druck/presión (bar)			
		1	2	3	4
<b>74125X</b>	portata/flow rate/débit/Wasserfluss/caudal (l/min)				
		3,8	4,4	4,6	4,8
		pressione/pressure/presion/druck/presión (bar)			
		1	2	3	4
<b>74140X</b>	portata/flow rate/débit/Wasserfluss/caudal (l/min)				
		3,8	4,8	5	5,1
		pressione/pressure/presion/druck/presión (bar)			
		1	2	3	4
<b>74130X</b>	portata/flow rate/débit/Wasserfluss/caudal (l/min)				
		3,3	4,6	5,2	5,1
		pressione/pressure/presion/druck/presión (bar)			
		1	2	3	4
<b>74135X</b>	portata/flow rate/débit/Wasserfluss/caudal (l/min)				
		4,5	4,3	4,6	4,6

## X-TREND INOX

art.

		pressione/pressure/presion/druck/presión (bar)			
		1	2	3	4
<b>2400X</b>	portata/flow rate/débit/Wasserfluss/caudal (l/min)				
		4,2	4,7	4,3	4,5
		pressione/pressure/presion/druck/presión (bar)			
		1	2	3	4
<b>2415X</b>	portata/flow rate/débit/Wasserfluss/caudal (l/min)				
		4,2	4,2	4,8	5

## REAL STEEL

art.

		pressione/pressure/pression/druck/presión (bar)			
<b>63420X</b>		<b>1</b>	<b>2</b>	<b>3</b>	<b>4</b>
		portata/flow rate/débit/Wasserfluss/caudal (l/min)			
		<b>6,8</b>	<b>9,8</b>	<b>12</b>	<b>14</b>
		pressione/pressure/pression/druck/presión (bar)			
<b>63421X</b>		<b>1</b>	<b>2</b>	<b>3</b>	<b>4</b>
		portata/flow rate/débit/Wasserfluss/caudal (l/min)			
		<b>7,2</b>	<b>10,3</b>	<b>12,8</b>	<b>14,9</b>
		pressione/pressure/pression/druck/presión (bar)			
<b>63422X</b>		<b>1</b>	<b>2</b>	<b>3</b>	<b>4</b>
		portata/flow rate/débit/Wasserfluss/caudal (l/min)			
		<b>6,7</b>	<b>9,6</b>	<b>11,8</b>	<b>13,7</b>
		pressione/pressure/pression/druck/presión (bar)			
<b>63425X</b>		<b>1</b>	<b>2</b>	<b>3</b>	<b>4</b>
		portata/flow rate/débit/Wasserfluss/caudal (l/min)			
		<b>5,9</b>	<b>8,6</b>	<b>10,8</b>	<b>12,7</b>
		pressione/pressure/pression/druck/presión (bar)			
<b>63435X</b>		<b>1</b>	<b>2</b>	<b>3</b>	<b>4</b>
		portata/flow rate/débit/Wasserfluss/caudal (l/min)			
		<b>4,6</b>	<b>6,7</b>	<b>8,3</b>	<b>9,6</b>
		pressione/pressure/pression/druck/presión (bar)			
<b>63435X</b>	GETTO N. 2 / JET N.2	<b>1</b>	<b>2</b>	<b>3</b>	<b>4</b>
		portata/flow rate/débit/Wasserfluss/caudal (l/min)			
		<b>4,6</b>	<b>6,6</b>	<b>8,3</b>	<b>9,7</b>



INDICE CODICI  
*ITEM INDEX*  
INDEX REFERENCES ARTICLES  
*ARTIKEL NUMMER INDEX*  
CLASIFICACION DE LOS CODIGOS

COD.	PAG.	COD.	PAG.	COD.	PAG.	COD.	PAG.	COD.	PAG.
107	127	16113	104	28716	65	68735	80	74100X	132
125	149	16113	111	28716	71	71720	74	74118X	134
2260	109	16123	110	28725	81	71721	74	74120X	132
2400	108	16124	147	28770	81	71725	75	74125X	132
2415	108	16801	103	30705	71	71730	74	74130X	133
2418	64	17432	123	30705	76	71731	75	74135X	133
2418	70	17964	76	30705	123	71820	68	74140X	133
2418	75	18056	104	30770	76	71821	68		
2418	80	18057	149	30870	71	71822	68		
2418	84	18314	104	31455	58	71823	69		
2418	89	18350	103	31456	136	71825	69		
2418	95	18357	103	31457	135	71830	69		
2418	102	19254	123	31458	135	71845	70		
2418	115	19429	110	31464	136	71850	70		
2418	122	19509	96	32106	65	72520	62		
2439	108	20915	111	32107	65	72521	62		
2460	109	22601	96	32115	65	72522	63		
3100	100	22715	97	32170	65	72525	62		
3101	100	22751	71	32173	65	72545	63		
3103	100	22751	97	32402	104	73300	52		
3110	101	22777	96	32403	56	73301	53		
3125	101	22778	96	32403	104	73302	56		
3140	101	24112	71	32405	56	73303	56		
3155	102	24112	76	32409	58	73304	55		
4319	120	24112	96	32411	57	73305	54		
4320	120	24583	142	32412	58	73306	55		
4325	120	24612	116	32413	58	16113S	116		
4340	121	24613	116	32432	57	33374X	136		
4345	121	24695	116	32440	58	16134X	142		
4370	121	24873	85	32470	58	16134X	147		
4371	122	25070	90	32471	57	2400X	146		
8550	126	25117	91	33307	136	2415X	146		
8650	126	25179	90	33309	135	2418X	141		
10140	149	25227	90	33311	135	2418X	146		
10775	110	25227	123	33317X	136	24581X	142		
11061	149	25228	90	33318	136	24582X	142		
11570	76	25228	123	63420	114	24591X	142		
11570	85	25922	90	63421	114	33308X	136		
12665	127	25922	103	63425	114	33310X	135		
14026	127	25922	116	63915	84	33312X	135		
14720	90	25922	123	63930	84	33370X	135		
14720	103	25925	81	64200	94	33371X	135		
14720	110	25943	103	64213	94	33372X	136		
14720	142	25973	65	64215	94	33373X	135		
14720	147	25973	71	65910	88	63420X	140		
15938	110	25973	96	65915	88	63421X	140		
16005	110	26000	85	65920	88	63422X	140		
16006	147	26011	85	65921	89	63425X	141		
16113	91	26018	85	65925	89	63435X	141		

## CONDIZIONI GENERALI DI VENDITA

1. Con la trasmissione dell'ordine il Cliente accetta tacitamente tutte le condizioni sottoesposte. Le vendite si intendono perfezionate solo dopo espressa approvazione della nostra azienda.
2. La merce è venduta al prezzo in vigore alla data della consegna. I termini di consegna si intendono approssimativi e quindi non impegnativi e non danno diritto alcuno a mancato pagamento o richiesta di risarcimento.
3. La merce viaggia a rischio e pericolo del committente anche se venduta a franco destino. La spedizione viene effettuata nel modo ritenuto più idoneo dalla ditta venditrice. All'atto della consegna il committente è tenuto alla verifica del materiale ordinato nonché al reclamo diretto al vettore in caso di manomissione o danneggiamento dell'imballo.
4. È fatta riserva assoluta di rendere del materiale senza nostra preventiva autorizzazione scritta.
5. Ogni reclamo e contestazione dovrà essere comunicato a mezzo lettera raccomandata entro e non oltre 5 giorni dalla data di ricevimento. In caso di reclamo effettuato in tempo utile, la merce dovrà esserci inviata franco nostro magazzino previo verifica dell'eventuale difetto. Nel caso di materiale riscontrato difettoso per cause a noi imputabili si provvederà alla sostituzione del prodotto restituito esclusa ogni ulteriore responsabilità della ditta venditrice per tutte le conseguenze dirette e indirette derivanti dalla installazione e dall'impiego.
6. In caso di ritardato pagamento verranno addebitati gli interessi commerciali a decorrere dal giorno successivo alla scadenza senza ausilio di diffide.
7. Le installazioni e le descrizioni contenute nei nostri stampati non comportano obbligo di fedele esecuzione, i dettagli e le misure contenute sono da considerarsi approssimative e soggette a modifiche senza preavviso.
8. In qualsiasi controversia la competenza esclusiva sarà del Foro di Vercelli.

Newform si riserva il diritto di apportare in qualunque momento, senza aggiornare tempestivamente questa pubblicazione, tutte quelle modifiche ai modelli, a scopo di miglioramento o per esigenze di carattere costruttivo.

Eventuali errori e/o refusi di stampa del presente listino non costituiscono motivo di contestazione.

## RUBINETTERIA COLORATA

Per evitare errori o ritardi di spedizione, negli ordini specificare sempre il "numero di riferimento" corrispondente al colore prescelto sul n/s campionario colori.

Per colori e finiture NON DI SERIE, Newform si riserva di:

- Verificare la fattibilità.
- Comunicare eventuali costi aggiuntivi.
- Stabilire adeguati tempi di consegna.

## PREZZI

Tutti i prezzi indicati si intendono in euro al netto di I.V.A. Il presente listino annulla e sostituisce tutti i precedenti.

## GENERAL CONDITIONS OF SALE

1. *The buyer, by placing a purchase order, unconditionally accepts all the conditions below. Sales are considered confirmed only after the express approval of our company.*
2. *Products are sold at the price applicable at the date of delivery. Terms of delivery are approximative and not binding and will not entitle the Buyer to claim compensation for any damages or indemnities of any kind.*
3. *The goods travel at risk and expense of the Buyer even if Delivered Duty Paid. The selling company chooses the most suitable shipment method. The Buyer must check at the time of the delivery and detect any discrepancies related to the packaging, quantity, type and integrity of the Products with notification to the carrier.*
4. *It is not allowed to return products without our prior written authorization.*
5. *Any complaint and dispute must be communicated by registered letter within 5 days from the receipt. In the event of a complaint made in due time, Products must be immediately sent to our warehouse to allow the completion of the necessary tests. In case of defective products due to production problems, the defective product will be replaced, excluding any further liability for damages and/or defects of the Products deriving from anomalies caused by, or connected to, the installation by the Buyer or by the final consumer.*
6. *In case of late payment, interest rates will be charged starting from the day following the deadline without any notice.*
7. *The installations and descriptions in our documents do not imply an obligation of faithful execution, the details, and measures here are to be considered approximate and subject to change without notice.*
8. *Any dispute related to the Products supplied to the Buyer shall be decided by the Court of Vercelli.*

*Newform reserves the right to modify all models for the purpose of improving them or for manufacturing needs, without prior notice to this publication and at any time.*

*Possible mistakes and/or misprints of current price list will not be object of dispute.*

## COLOURED ITEMS

*In order to avoid mistakes or delays in shipping please always specify the reference number related to your choice based our colour table.*

*For DIFFERENT colours and finishings, Newform reserves the possibility:*

- *To accept the order.*
- *To review the price.*
- *To adjust delivery time.*

## PRICES

*All prices do not include VAT. The present price list cancels and replaces all previous ones.*

## CONDITIONS GÉNÉRALES DE VENTE

1. Lors de la transmission de la commande, le Client accepte tacitement toutes les conditions énoncées ci-dessous. Les ventes ne sont pas considérées comme conclues qu'après l'accord exprès de notre société.
2. Les prix des marchandises vendues sont ceux en vigueur au jour de la date de livraison. Les conditions de livraison s'entendent approximatives et donc non contraignantes et ne donnent aucun droit au non-paiement ou à une demande d'indemnisation.
3. Le risque du transport est supporté en totalité par l'acheteur, même si les marchandises sont vendues « rendu droits acquittés ». L'expédition est effectuée de la manière jugée la plus appropriée par la société de vente. Lors de la livraison, le client est tenu de vérifier le matériel commandé ainsi que de déposer une réclamation directe auprès du transporteur en cas d'altération ou de détérioration de l'emballage.
4. Il est absolument interdit de retourner du matériel sans notre autorisation écrite préalable.
5. Toute réclamation et contestation doit être communiquée par courrier recommandée AR dans un délai maximal de 5 jours à compter de la date de réception. En cas de réclamation dans les délais impartis, la marchandise doit nous être envoyée pour qu'on puisse effectuer des tests. Dans le cas d'un produit jugé défectueux pour des raisons qui nous sont imputables, le produit retourné sera remplacé, excluant toute responsabilité supplémentaire de la société de vente pour toutes les conséquences directes et indirectes découlant de l'installation et de l'utilisation.
6. En cas de retard de paiement, les intérêts commerciaux seront facturés à compter du jour suivant la date limite sans l'aide d'avertissements.
7. Les installations et les descriptions dans nos documents n'impliquent pas d'obligation d'exécution fidèle, les détails et les mesures doivent être considérées comme approximatives et soumis à changement sans préavis.
8. Tout litige relatif à l'interprétation et à l'exécution des présentes conditions générales de vente est soumis au Tribunal de Vercelli.

Newform s'accorde le droit de modifier ses modèles à tout moment, sans mettre à jour immédiatement cette publication, à des fins d'amélioration ou de production.

Toute erreur et/ou fautes de frappe de ce tarif ne sont pas motif de réclamation.

## ARTICLES COLORÉS

Afin d'éviter des erreurs d'expédition ou des retards, indiquez toujours le "numéro de référence" correspondant à la finition choisie sur nos documents.

Pour les finitions qui ne sont pas de série, Newform se réserve le droit de:

- Vérifier la faisabilité.
- Communiquer d'éventuels coûts supplémentaires.
- Définir de nouveaux délais de livraison.

## PRIX

Tous les prix sont en euros et calculés hors taxes. Ces tarifs publics annulent et substituent les précédents.

## ALLGEMEINE GESCHÄFTSBEDINGUNGEN FÜR DEN VERKAUF

1. Mit der Sendung der Bestellung akzeptiert der Kunde stillschweigend alle unten ausgeführten Bedingungen. Die Verkäufe sind erst dann abgeschlossen, wenn unser Unternehmen die Bestellung ausdrücklich angenommen hat.
2. Die Ware wird zum am Lieferdatum gültigen Preis verkauft. Die Lieferfristen sind nicht bindend und berechtigen nicht zur Zahlungsunterlassung oder Kostenrückerstattung.
3. Die Ware reist auf Risiko und Gefahr des Auftraggebers, auch wenn Sie frei Haus geliefert wird. Die Spedition erfolgt auf die nach dem Ermessen des Verkäuferunternehmens geeignetste Weise. Bei der Aushändigung der Ware ist der Auftraggeber verpflichtet, das bestellte Material zu prüfen und Manipulation oder Beschädigung der Verpackung direkt beim Frachtführer zu beanstanden.
4. Ohne unsere vorherige schriftliche Genehmigung darf auf keinen Fall das Material zurückgeschickt werden.
5. Jede Reklamation oder Beanstandung muss per Einschreiben innerhalb von 5 Tagen ab dem Erhalt der Ware mitgeteilt werden. Bei einer fristgerechten Reklamation muss die Ware frei Lager zurückgeschickt werden und wird auf den Mangel geprüft. Wenn das Material einen Mangel aufweist, der uns zugeschrieben werden kann, wird das zurückgeschickte Produkt unter Ausschluss jeder weiteren Haftung für alle direkten und indirekten Folgen durch die Installation und die Verwendung ausgetauscht.
6. Bei Zahlungsverzögerungen werden Verzugszinsen ab dem auf den Ablauf der Zahlungsfrist folgenden Tag berechnet, ohne dass es einer Abmahnung bedarf.
7. Die in unseren Druckerzeugnissen enthaltenen Installationen und Beschreibungen sind unverbindlich, die angegebenen Details und Maße sind als annähernd zu betrachten und können ohne Vorankündigung geändert werden.
8. Alle Rechtsstreitigkeiten werden ausschließlich vor dem Gericht Vercelli gebracht.

Newform behält sich das Recht vor, zu jedem Zeitpunkt ohne fristgemäße Aktualisierung dieser Publikation alle zur Verbesserung oder wegen bautechnischen Anforderungen notwendigen Änderungen an den Modellen vorzunehmen.

Etwas Irrtümer und/oder Druckfehler in dieser Preisliste sind kein Grund zur Beanstandung.

## FARBIGE ARMATUREN

Um Versandfehler oder -verzögerungen zu vermeiden, muss immer die „Referenznummer“ für die gewählte Farbe auf unseren Farbmustern angegeben werden.

Für Farben und Oberflächen, die NICHT STANDARD sind, behält sich Newform das Recht vor:

- Überprüfung der Machbarkeit.
- Informieren über eventuelle weitere Kosten.
- Festlegung der Lieferzeiten.

## PREISE

Alle Preise sind in Euro und ohne Mehrwertsteuer. Diese Preisliste annulliert und ersetzt alle vorherigen Preislisten.

## CONDICIONES GENERALES DE VENTA

1. Con la transmisión del pedido, el Cliente acepta tácitamente todas las condiciones expuestas a continuación. Las ventas se consideran perfeccionadas solo después de la aprobación expresa de nuestra empresa.
2. La mercancía se vende al precio vigente en la fecha de entrega. Los plazos de entrega son aproximados y, por lo tanto, no vinculantes y no dan derecho a ningún tipo de falta de pago o solicitud de indemnización.
3. La mercancía viaja por cuenta y riesgo del cliente, incluso si se vende con entrega en el destino. El envío se realiza de la manera que la empresa vendedora considere más adecuada. En el momento de la entrega, el cliente está obligado a verificar el material solicitado, así como a reclamar directamente al transportista en caso de manipulación o daño del embalaje.
4. Está absolutamente reservado el derecho de devolver material sin nuestra autorización previa por escrito.
5. Todas las quejas y reclamaciones deberán comunicarse por carta certificada en un plazo máximo de 5 días a partir de la fecha de recepción. En caso de reclamación efectuada a su debido tiempo, la mercancía deberá ser enviada franco nuestro almacén previa comprobación del eventual defecto. En el caso de material encontrado defectuoso por causas imputables a nosotros, se procederá a la sustitución del producto devuelto, excluyendo cualquier responsabilidad adicional de la empresa vendedora por todas las consecuencias directas e indirectas derivadas de la instalación y el uso.
6. En caso de retraso en el pago, se cobrarán los intereses comerciales a partir del día siguiente al vencimiento sin la mediación de avisos.
7. Las instalaciones y las descripciones contenidas en nuestro material impreso no implican obligación de fiel ejecución, los detalles y las medidas contenidas son aproximadas y están sujetas a cambios sin previo aviso.
8. Ante cualquier controversia, la competencia exclusiva será del Tribunal de Vercelli.

Newform se reserva el derecho de realizar en cualquier momento, sin actualizar oportunamente esta publicación, todas las modificaciones de los modelos que considere con fines de mejora o por necesidades de fabricación.

Los eventuales errores y/o erratas de impresión de este catálogo no constituyen motivo de reclamación.

## GRIFERÍA DE COLOR

Para evitar errores o retrasos en el envío, en los pedidos especifique siempre el "número de referencia" correspondiente al color elegido de nuestro muestrario de colores.

Para colores y acabados NO ESTÁNDAR, Newform se reserva el derecho de:

- Comprobar su viabilidad.
- Comunicar cualquier coste adicional.
- Establecer plazos de entrega adecuados.

## PRECIOS

Todos los precios indicados se entienden en euros sin IVA. Este catálogo anula y sustituye a todos los anteriores.





DESIGN MAKES RESPONSIBLE

## SISTEMA DI QUALITÀ CERTIFICATO

Lo scopo prioritario di Newform è quello di fornire un prodotto di qualità superiore, progettato minuziosamente e costruito solamente con materiali di prima scelta, una metodologia certificata secondo le norme UNI-EN ISO 9001 per la progettazione e produzione di rubinetteria sanitaria e accessori da bagno. Inoltre, la creazione e l'implementazione di un sistema integrato che permette sistematicamente di migliorare le condizioni lavorative e di ridurre l'impatto ambientale secondo gli standard ISO 45001 ed ISO 14001, è un altro importante passo verso una sempre più consapevole responsabilità sociale d'impresa.

### CERTIFIED QUALITY SYSTEM

*Newform's first priority is to create high quality products, conceived carefully in every single detail and produced only with first quality materials, a method recognised by UNI-EN ISO 9001 standards for design and production of sanitary taps and bathroom accessories. Furthermore, creation and implementation of an integrated system to continuously improve working conditions and reduce environmental impact according to ISO 45001 and ISO 14001 standards is another important step towards Corporate Social Responsibility.*

### SISTÈME DE QUALITÉ CERTIFIÉ

L'exigence prioritaire de Newform est de produire des objets de qualité supérieure, produits exclusivement avec des matériaux de premier choix et selon un processus de production certifié ISO-ES 9001. De plus, nous avons créé un système intégré qui permet une amélioration constante des conditions de travail et une réduction constante de l'impact de la production sur l'environnement selon les standards de production ISO 45001 et ISO 14001 garantissant ainsi la responsabilité sociale de notre entreprise vis-à-vis de ses employés mais aussi de ses clients.

### ZERTIFIZIERTES QUALITÄTSSYSTEM

*Das Hauptziel von Newform ist es, ein Produkt von höchster Qualität zu liefern, das sorgfältig entworfen und nur mit Materialien erster Wahl gebaut wird, die gemäß den UNI-EN ISO 9001 Zertifizierung für Design und die Produktion von Sanitärarmaturen und Badezimmerzubehör entspricht. Darüber hinaus sind die Schaffung und Implementierung eines integrierten Produktionsverfahren, das die systematische Verbesserung der Arbeitsbedingungen und die Verringerung der Umweltbelastung gemäß den Normen ISO 45001 und ISO 14001 ermöglicht, ein weiterer wichtiger Schritt in Richtung einer zunehmend bewussteren sozialen Verantwortung von Unternehmen.*

### SISTEMA DE CALIDAD CERTIFICADO

El objetivo prioritario de Newform es proporcionar un producto de calidad superior, diseñado minuciosamente y construido únicamente con materiales de primera calidad, una metodología certificada según las normas UNI-EN ISO 9001 para el diseño y la fabricación de grifería sanitaria y accesorios de baño. Además, la creación e implementación de un sistema integrado que permite sistemáticamente mejorar las condiciones de trabajo y reducir el impacto ambiental según las normas ISO 45001 e ISO 14001, Es otro paso importante hacia una responsabilidad social cada vez más consciente de la empresa.





www.newform.it  
newform@newform.it

---

NEWFORM S.p.A.  
via Marconi, 25/A  
Frazione Vintebbio  
13037 Serravalle Sesia (VC) Italy  
Phone: +39 0163 452011 (r.a.)

**Direzione Creativa / Creative Direction / Direction créative  
Kreative Richtung / Dirección Creativa: Newform**

Le immagini ambientate presenti sul catalogo hanno il solo scopo di enfatizzare il design dei prodotti e non garantiscono l'effettiva fattibilità.

Per l'installazione avvalersi, quindi, della consulenza di un professionista del settore.

I colori rappresentati nelle immagini sono puramente indicativi.

L'azienda si riserva in qualunque momento di apportare senza preavviso modifiche a prodotti e accessori.

Eventuali errori e/o refusi di stampa del presente listino non costituiscono motivo di contestazione.

*The images in the catalogue are intended to emphasise the design of the products and do not guarantee actual feasibility. For installation, consult a professional in the field.*

*The colours shown are just an indication.*

*The Manufacturer reserves the right to modify products and accessories at any time without prior notice.*

*Possible mistakes and/or misprints of current price list will not be object of dispute.*

Les photos présentes dans le catalogue visent uniquement à souligner le design des produits et elles ne garantissent pas la faisabilité concrète. Donc, pour l'installation, veuillez recourir aux conseils d'un professionnel du secteur.

Les couleurs des images présentées sont à considérer purement indicatives.

La société se réserve le droit d'apporter toute modification aux articles et accessoires à tout moment et sans préavis.

Toute erreur et/ou fautes de frappe de ce tarif ne sont pas motif de réclamation.

*Die Umgebungsbilder im Katalog haben nur den Zweck, das Design der Produkte hervorzuheben und stellen keine Garantie für die tatsächliche Machbarkeit dar. Nehmen Sie daher für die Installation den Rat eines Fachmanns der Branche in Anspruch.*

*Die in den Bildern gezeigten Farben sind nur Richtwerte.*

*Das Unternehmen behält sich das Recht vor, jederzeit ohne Vorankündigung Änderungen an Produkten und Zubehör vorzunehmen.*

*Etwaige Irrtümer und/oder Druckfehler in dieser Preisliste sind kein Grund zur Beanstandung.*

Las imágenes ambientadas en el catálogo tienen el único propósito de destacar el diseño de los productos y no garantizan la viabilidad real. Por esta razón, recurra para la instalación al asesoramiento de un profesional del sector.

Los colores representados en las imágenes son meramente indicativos.

La empresa se reserva el derecho en cualquier momento de realizar cambios en los productos y accesorios sin previo aviso.

Los eventuales errores y/o erratas de impresión de este catálogo no constituyen motivo de reclamación.





[newform.it](http://newform.it)